

EnerGenius® 2

12 to 240 Volts Nominal, 6 to 150 Amps
Automatic Battery Charger & DC Supply



New Generation SCR Industrial/Utility Charger

Full digital control, self-diagnostics & communications

**Optional Modbus
and DNP3**

**Compatible with first
generation IQ chargers**

**Industry-leading
5-year warranty**

Contact
Stored Energy Systems LLC
Longmont, Colorado, USA

www.sens-usa.com
(303) 678-7500
info@sens-usa.com

CAD drawings, firmware,
certifications, and technical
documentation are available
on our website.



SCR Power + State-of-the-art Features

IQ2 is an SCR-type industrial/utility charger that powers DC equipment, charges your battery, automatically tests battery performance, and communicates DC system status. IQ2 is an update of SENS' popular EnerGenius IQ charger.

IQ2 is fit, form and function compatible with the original EnerGenius IQ. Employing the same powertrain as the original EnerGenius IQ, IQ2 adds the advanced DSP-based control and firmware proven in thousands of SENS' MicroGenius and EnerGenius DC platforms.

First generation EnerGenius IQ chargers can be easily upgraded to full IQ2 function by swapping circuit boards and the front door mimic panel/LED overlay.

Demonstrating SENS' commitment to quality and to surviving harsh industrial and utility environments, IQ2 is equipped with SENS' unique corrosion-proof all stainless-steel housing and backed by industry-best five-year warranty.

Features & Benefits

Stainless steel construction

No rust and no paint to touch up. Resists corrosion far better than materials used in competing products.

Industry's best warranty coverage

The entire charger is warranted for five years.



Patented charging performance

IQ2 patented charging features deliver the industry's fastest and safest charging that, in some applications, nearly double battery life.

LED system mimic panel

Provides system status at a glance, now including ground fault indication.

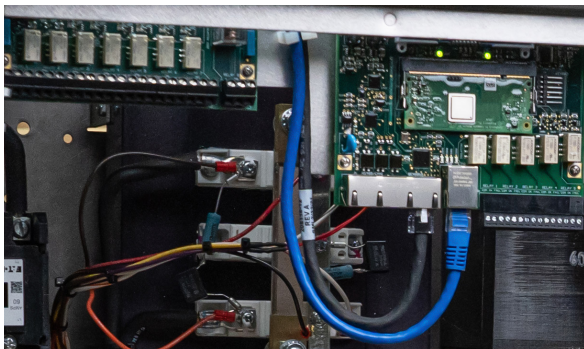
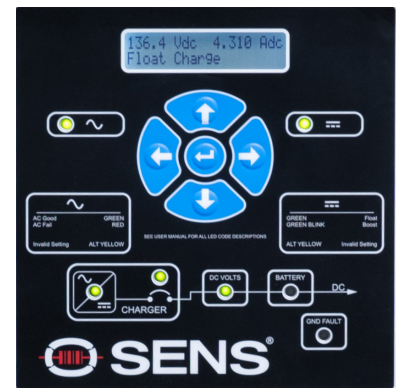

Advanced functions, proven in service

IQ2 employs the same DSP-based architecture, firmware and digital data bus proven in thousands of SENS switchmode power systems.

More versatile

IQ2 meets all specs as the original EnerGenius IQ, and more. New spec compliance includes Process Industry Practices (PIP) and more flexible alarm relay configurations.

Integrated battery check cuts risk of failure

Lead-acid batteries frequently fail without warning. The on-board battery check system determines if your battery can support a connected continuous load without taking the battery offline or shutting down the charger.

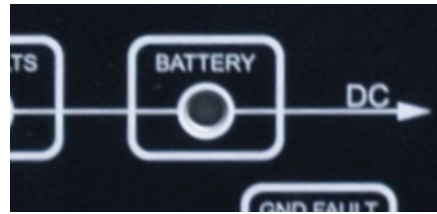

Constant voltage, current limited, filtered DC

Simultaneously supplies filtered DC to critical loads, recharges the connected system battery and automatically maintains flooded lead-acid, NiCd or lithium batteries in peak condition.

Upgradable from the original to IQ2

IQ2 is fit, form and function compatible with first generation IQ chargers. The easy upgrade of first generation IQ chargers enables all new functions at much lower cost than a new charger.

Housing Dimensions

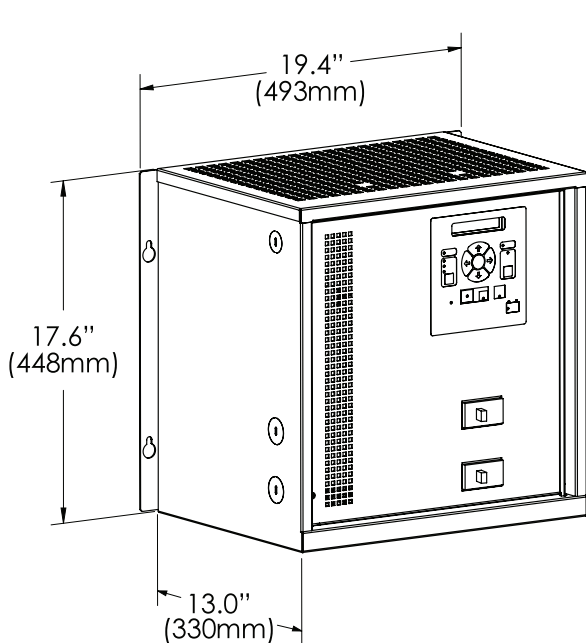

Housing size Q1

Wall mount configuration
(19" rack mount also available)

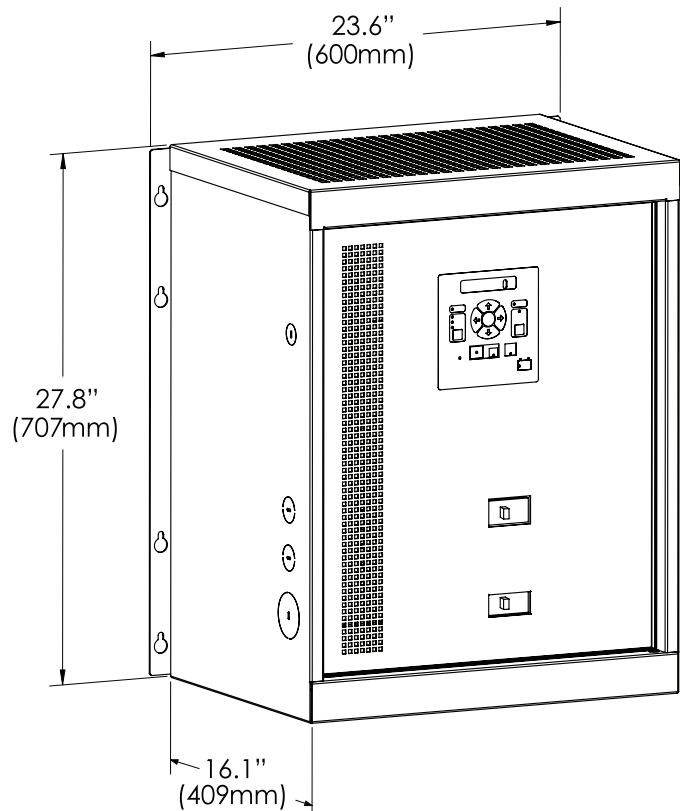

Housing size Q2

Wall mount configuration
(add 3.75" [95.25mm] height for free-standing option, 23" rack mount also available)

EnerGenius IQ2 Charger

Specifications

		Filtered ¹ 511	Eliminator ² 512	Eliminator Plus ³ 514	Extreme ⁴ 534
DC Output	12, 24, 48 110/120 or 220/240VDC nominal	Lead-acid, NiCd, NaCl (salt) or lithium			
	Line and load voltage regulation	+0.25%			
	Batt temp comp w/ adjustable slope and expert system	Std			
	Adjustable current limit to 100%	Std			
	Output ripple:				
	60Hz: standard filter: 12, 24, 48V DC (on/off battery ⁵)	30mV / 480mV	N/A		
	60Hz: standard filter: 120V DC (on/off battery)	100mV / 2%	N/A		
	60Hz: standard filter: 240V DC (on/off battery)	200mV / 2%	N/A		
	60Hz: battery eliminator filter: 12-120V DC (on/off battery)	N/A	30mV / 100 mV		
	60Hz: battery eliminator filter: 240V DC (on/off battery)	N/A	30mV / 200 mV		
	50Hz: standard filter: 12, 24, 48V DC (on battery)	1%	30mV		
	50Hz: standard filter: 120V DC (on battery)	1%	100mV		
	50Hz: standard filter: 240V DC (on battery)	1%	200mV		
Timed commission charge w/ auto revert to std settings	Std				
AC Input	120/208/240VAC, field selectable standard ⁶	Others optional			
User Interface	2 x 20 backlit LCD plus LED mimic panel	Std			
	Float, auto & manual boost charging modes and LEDs	Std			
	Manual & automatic boost charge timer 0-256 hours	Std			
	All parameters keypad adjustable, with keypad lock	Std			
Meters	1% accy digital DC V & A meters; AC V meter	Std			
	DC voltmeter displays both volts/cell and total voltage	Std			
Remote Alarms & Communications	Alarm status via summary Form C contact	Std			
	Alarm status via individual programmable Form C contacts	Optional			
	Analog data & alarm status via data communications	Optional			
	Individual programmable Form C contacts + data communications	Optional			
Battery Check	Fully adjustable automatic battery check system	Std			
Safety & Reliability Features	Dynamic Boost™ charge control	Std			
	60Hz units NEMA PE-5/IEEE 2405 compliant & high efficiency	Std			
	2-pole AC circuit breaker, 10K AIC	Std	N/A		
	2-pole AC circuit breaker, 18-25K AIC, w/ inrush limiter	N/A	Std		
	2-pole AC circuit breaker, 65K AIC, w/ inrush limiter	N/A	Factory option ⁷		
	2-pole UL Listed DC circuit breaker	Std			
	Electronic soft start & programmable start delay	Std			
	Backwards battery protection	Alarm	Alarm + diode		
	Dual-microprocessor architecture	Std			
	All-digital design - no potentiometers	Std			
	Conformal coated; surface-mount technology circuit cards	Std			
	Redundant and selective over voltage shutdown	Std			
	-40C to +50C operating temp with overtemp current cutback	Std			
	Boost pilot relay ⁸	Std			
	Battery temperature compensation	Std			
	Remote battery temperature compensation ⁹	Optional			
	Digital load and mode sharing system ¹⁰	Optional			
	Surge withstand: ANSI 62.41, ANSI C37.90, IEC 61000-6-2	Std			
	Blocking diode & reverse polarity protection diode	N/A	Std		
	Display and alarm relay test	Std			
Industry Standards & Agency Compliance	60Hz units: C-UL listed to UL and CSA standards ¹¹	Std			
	50/60Hz units: C-UL listed + CE marked ¹¹	Std			
	3rd party certified to IBC 2006-2021; Sds value of 2.50g ¹²	Std			
	OSHPD seismic pre-approval ¹²	Factory option			
	ABS Type Approved. Meets USCG requirements ¹³	Std			
	RF emissions: FCC Part 15 Class A; EN 61000-6-4	Std			
	RF immunity: EN 61000-6-2	Std			
	Process Industry Practices (PIP) compliance	Optional (includes wire markers, high current relay and breaker locks)			
Mechanical	NEMA 1, IP 20 protection rating	Std			
	Rugged stainless steel housing	Std			
	Drip shield (IP21 and IP22 options)	Optional			

"Std" = standard feature. "N/A" = not available. "Factory option": factory installed option only. "Optional": Feature can be installed in the system at any time. (1) Lowest cost package. (2) Specify for lower output ripple. (3) Adds reverse polarity protection and blocking diodes to Eliminator package. (4) Specify for sites with heavier electrical transients and/or where AC supply is of low impedance. (5) "On battery" ripple measured at the terminals of a battery rated in AH > 4 times charger's amp rating. "Off battery" ripple measured at the load end of charger output cables. (6) On units rated < 3.4KW output. Higher power units require either field selectable 208/240 input or single input voltage. See last page for details. (7) Configure any desired relay as a pilot relay. Factory configuration for Boost requires Remote Alarms & Communications Feature Package C or N (see ordering section). (8) Requires optional remote temp sensor or SENS battery monitor. (9) Requires optional load share accessory. (10) Listed to UL 1012 and CSA 22.2 No. 107.2. Listing to UL 1236 is special order option for 12 and 24 volt chargers. (11) Wall-mount units only. (12) May require optional IP22 dripshield to meet USCG requirements.

How To Order

Product Type	DC Volts	Output Current	AC Volts	Agency Marks	Feature Pkg	Alarms/Comms	Mount
Q	024	050	T	L	514	A	
(A)	(B)	(C)	(D)	(E)	(F)	(G)	(H)

	Parameter	Code	Value
(A)	Product Type	Q	EnerGenius IQ
(B)	DC Output Voltage	012 024 048 120 240	12VDC nom. 24VDC nom. 48VDC nom. 120VDC nom. 240VDC nom.
(C)	Output Current	006 012 016 025 035 050 075 100 150	6A 12A (smallest 12VDC charger) 16A 25A (largest 240VDC charger) 35A 50A (largest 120VDC charger) 75A 100A (largest 12 & 48VDC chargers) 150A (largest 24VDC charger)
(D)	AC Input Voltage	T P Z 8 4 V	115-120/208/230-240V, 60Hz 115-120/208/230-240V, 50/60Hz 208/230-240V, 60Hz (> 3.4KW output power) 480V, 60Hz 230V, 50/60Hz (> 3.4KW output power) 400V, 50/60Hz
(E)	Agency Marks	L G H J	C-UL 1012 listed (60Hz units) C-UL 1012 listed & CE marked (50/60Hz units) C-UL 1236 listed (60Hz units) C-UL 1236 listed & CE marked (50/60Hz units)
(F)	Feature Package ¹	511 512 514 534 574	Filtered package: Standard input breaker and standard output filter Eliminator package: Adds lower ripple filter to Filtered package Eliminator Plus package: Adds reverse polarity diode and blocking diode to Eliminator package Extreme package: Adds inrush limiter to Eliminator Plus package and upgrades input breaker to 18-25K AIC rating Extreme package: Upgrades input breaker in 534 to 65K AIC. Available only in Q2 housing
(G)	Remote Alarms & Communications Feature Packages	A C M N P S	Summary Form C alarm (30V/2A) ² 7 Form C alarms (30V/2A) ² & 1 Form C alarm (120VAC/5A) 5 Form C alarms (30V/2A) ³ & Modbus 10/100Base-T and RS-485 Options C and M 5 Form C alarms (30V/2A) ³ & DNP3 10/100Base-T and RS-485 Options C and P
(H)	Mounting	(Blank) E R	Wall mount or optional free-standing Q2 OSHPD pre-approved (wall mount units only) Relay rack mount (factory installed option only)

(1) "5" indicates standard NEMA PE-5/IEEE 2405 compliance. Replace "5" with "6" to add PIP compliance. PIP requires Remote Alarms & Communications Feature Package C or N. (2) Terminal blocks accept 14-24AWG wire. (3) Terminal blocks accept 16-28AWG wire.

Optional Features

- Freestanding, floor-mounting housing (size Q2 only): Order p/n 209399
- Drip shield: Order 209320 for IP21 Q1, 209321 for IP21 Q2, 209324 for IP22 Q1, or 209325 for IP22 Q2
- Remote temperature sense cable: Order p/n 209481
- Load share accessory: Order p/n 209069
- Optional charger packaging: relay racks or cabinets (NEMA 1 and NEMA 3R). Contact factory.

Ratings

Inputs, Circuit Breakers, Weights, and Dimensions

Output		Model number	Input ratings		AC, DC breaker amps ^c	Case size & shipping weight		
			Input voltage ^a	Input current, worst case ^b		Case	Lbs	Kg
V	A							
12	12	Q012-012	120/208/240 ^a , 480	3.2, 1.8, 1, 6, 0.8	15 ^a , 15, 15	Q1	92	42
12	25	Q012-025	120/208/240 ^a , 480	6.3, 3.6, 3.1, 1.6	15 ^a , 15, 35	Q1	96	44
12	50	Q012-050	120/208/240 ^a , 480	13, 7.2, 6.3, 3.1	20 ^a , 15, 70	Q2	120	55
12	100	Q012-100	120/208/240 ^a , 480	24, 14, 12, 6.1	30 ^a , 15, 125	Q1	298	135
24	6	Q024-006	120/208/240 ^a , 480	2.9, 1.7, 1.5, 0.7	15 ^a , 15, 10	Q1	92	42
24	12	Q024-012	120/208/240 ^a , 480	5.6, 3.2, 2.8, 1.4	15 ^a , 15, 15	Q1	96	44
24	16	Q024-016	120/208/240 ^a , 480	7.4, 4.3, 3.7, 1.8	15 ^a , 15, 20	Q1	104	47
24	25	Q024-025	120/208/240 ^a , 480	12, 6.7, 5.8, 2.9	15 ^a , 15, 35	Q1	119	54
24	35	Q024-035	120/208/240 ^a , 480	16, 9.1, 7.9, 4	20 ^a , 15, 45	Q1	129	59
24	50	Q024-050	120/208/240 ^a , 480	23, 13, 11, 5.6	30 ^a , 15, 70	Q1	134	61
24	75	Q024-075	120/208/240 ^a , 480	33, 19, 17, 8.3	45 ^a , 15, 100	Q2	308	140
24	100	Q024-100	120/208/240 ^a , 480	44, 25, 22, 11	60 ^a , 15, 125	Q2	320	145
24	150	Q024-150	208/240 ^a , 480	37, 32, 16	50 ^a , 20, 200	Q2	354	161
48	6	Q048-006	120/208/240 ^a , 480	5.2, 3, 2.6, 1.3	15 ^a , 15, 10	Q1	96	44
48	12	Q048-012	120/208/240 ^a , 480	10, 5.9, 5.1, 2.6	15 ^a , 15, 15	Q1	108	49
48	16	Q048-016	120/208/240 ^a , 480	13, 7.7, 6.7, 3.3	20 ^a , 15, 20	Q1	122	55
48	25	Q048-025	120/208/240 ^a , 480	21, 12, 10, 5.2	30 ^a , 15, 35	Q1	148	67
48	35	Q048-035	120/208/240 ^a , 480	29, 17, 14, 7.1	40 ^a , 15, 45	Q1	167	76
48	50	Q048-050	120/208/240 ^a , 480	40, 23, 20, 10	50 ^a , 15, 70	Q1	190	86
48	75	Q048-075	208/240 ^a , 480	34, 30, 15	45 ^a , 20, 100	Q2	335	152
48	100	Q048-100	208/240 ^a , 480	45, 39, 20	60 ^a , 25, 125	Q2	360	164
120	6	Q120-006	120/208/240 ^a , 480	12, 7, 6.1, 3.1	15 ^a , 15, 15	Q1	130	59
120	12	Q120-012	120/208/240 ^a , 480	24, 14, 12, 5.9	30 ^a , 15, 15	Q1	152	69
120	16	Q120-016	120/208/240 ^a , 480	31, 18, 16, 7.8	40 ^a , 15, 20	Q1	186	85
120	25	Q120-025	120/208/240 ^a , 480	47, 27, 24, 12	60 ^a , 15, 35	Q1	210	95
120	35	Q120-035	208/240 ^a , 480	38, 33, 17	50 ^a , 25, 45	Q2	322	146
120	50	Q120-050	208/240 ^a , 480	54, 46, 23	70 ^a , 30, 70	Q2	375	170
240	6	Q240-006	120/208/240 ^a , 480	24, 14, 12, 5.9	30 ^a , 15, 15	Q1	150	68
240	12	Q240-012	120/208/240 ^a , 480	44, 26, 23, 11	60 ^a , 15, 15	Q1	210	95
240	16	Q240-016	208/240 ^a , 480	35, 30, 15	45 ^a , 20, 20	Q2	320	140
240	25	Q240-025	208/240 ^a , 480	54, 46, 23	70 ^a , 30, 35	Q2	375	170

^a Indicates standard input voltage configuration. Standard input voltage configuration for 50/60Hz units is either field selectable 120/208/220-240VAC or 230 volts. Circuit breaker ratings are identical for field selectable units. 400VAC, 50/60Hz is available on special order. ^b Current ratings shown are for respective input voltages. Current consumption at nominal input voltage is 8-13% less than worst case value shown, depending on model. ^c Numbers in black show AC input breaker ratings that correspond to input voltage options. Number in blue shows DC output breaker rating.

Contact Information

Sales 1.866.736.7872 • 303.678.7500 • info@sens-usa.com • www.sens-usa.com
 Stored Energy Systems, LLC Longmont, CO 80501 USA

Contact SENS or your local sales representative for additional specification, engineering and installation information, or visit SENS' website for latest available data. Specification subject to change without notice.
 SENS, Stored Energy Systems, the battery/rectifier logo are trademarks of Stored Energy Systems LLC. This product is covered by one or more patents: www.sens-usa.com/patents.