

BPS 63

Weatherproof DC Battery Power System



Complete, non-stop DC power in a compact package

- **Applications** – PCS repeaters, SCADA, process control, utilities
- **Outdoor cabinet** – eliminates need for equipment shelter
- **Single system responsibility** – includes charger, battery, low volt disconnect
- **Temperature compensated charging** – gives longest battery life
- **Filtered DC output** – is ideal for electronic loads
- **Standard alarm system** – provides complete status on charger and battery



SENS BPS 63 is a factory packaged DC battery power system that provides non-stop DC power to critical loads. The non-corroding, weatherproof cabinet eliminates the need for equipment shelters. SENS BPS 63 is specified and used in a wide variety of applications including communications, SCADA, process control and switchgear backup by wireless communication providers, oil companies, industrial manufacturers, utilities and government entities.

BPS 63 Specifications

System configurations

DC Volts	Charger Amps	VRLA Battery AH
12	6, 12 or 25	65, 100 or 200
24	6, 12 or 25	65 or 100
48	6 or 12	35

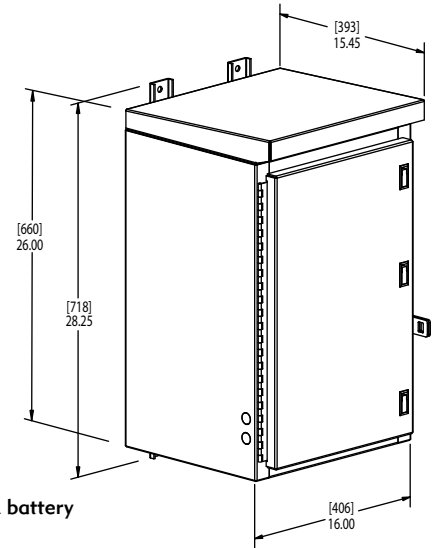

Charger AC input, single-phase

Standard 50/60 Hz input
Voltage, frequency tolerance
Input protection

Field selectable 115/230 VAC, 50/60 Hz
Voltage $\pm 10\%$, frequency $\pm 5\%$
2-pole circuit breaker, soft start, transient protection

Charger output

Regulation
Current limit
Charge characteristic
Output filtering
Temperature compensation
Output protection

$\pm 1\%$ of the correct temperature compensated value
100% to 105% of rated current
Constant voltage, current limited, single rate for VRLA battery
30 mV rms on battery
Standard, $-0.2\%/degree\ C$ slope
Current limit, 2-pole circuit breaker, overvoltage shutdown, surge suppression

User interface, indication, alarms and controls

Output indication
Status indication
Alarm indications

Test points for system voltage and charger output current
LED indicators for AC mode, float mode, boost mode, low voltage load disconnect
LED indicators plus Form C contacts for AC fail, low DC volts, high DC volts, charger fail, summary alarm

Alarm contacts rating
Alarm test

2A at 26 VDC, 0.5A at 120 VAC, resistive
Alarm LED test button activates all LEDs

Electrical and environmental protection systems

Battery undervolt protection
Mechanical and corrosion protection

Standard low volt load disconnect
Ventilated NEMA 4 aluminum cabinet with high gloss white powder coat
Circuit boards and exposed conductors coated with a flexible long life sealant to prevent corrosion
-20C to +50C, 5% to 95% R.H. Optional battery heater recommended for cold climates
Thermostatic fan control operates fan only when warm. Note: Extended operation above room temperature shortens battery life

Ambient rating

Optional features

Charge mode
Thermostat controlled heater

Optional automatic dual rate charging for cyclic applications
Warms battery to allow operation down to $-40C$

Model number breakout

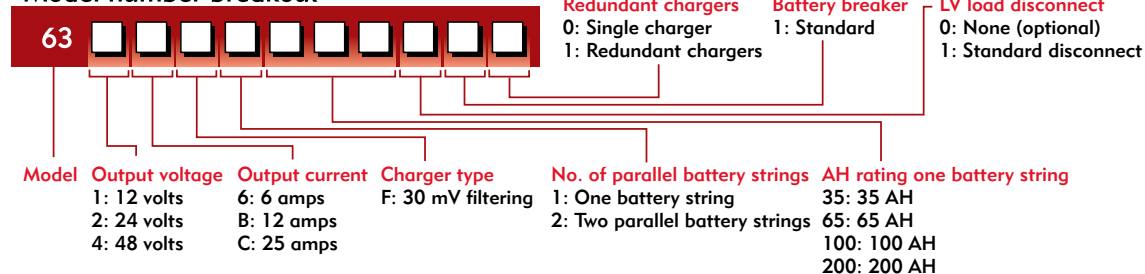

Additional Information

Contact SENS for additional information. Specification is subject to change without notice.



Contact Information

For information and service on any SENS product, please contact us at:
Sales 1.866.736.7872 • 303.678.7500 • Fax 303.678.7504
www.sens-usa.com • info@sens-usa.com
1840 Industrial Circle, Longmont, CO 80501 USA

