

# CommsGenius Load Sharing and Modbus Communications

*For the SENS EnerGenius IQ*



---

SENS Part Number: 101316  
Document Revision: B  
DCN Number: 105945  
Date: December 15, 2010



Installation or service questions?  
Contact your charger supplier or call SENS at  
1.800.742.2326 (303.678.7500)  
between 8 a.m. and 5 p.m. (Mountain Time)  
Monday through Friday, or visit our website at  
[www.sens-usa.com](http://www.sens-usa.com).

**TABLE OF CONTENTS**

<b>1</b>	<b>CommsGenius Description and Function Summary</b> .....	1
1.1	Data Communications Function .....	1
1.1.1	USB Maintenance Port – Local Communication .....	1
1.1.2	Modbus Network – Remote Communication.....	2
1.2	Dual IQ Charger Synchronizing and Load Share Functions .....	2
1.3	CommsGenius On-Board Battery.....	2
<b>2</b>	<b>Initial Hardware Setup</b> .....	3
2.1.	Setup CommsGenius Network Connections .....	3
2.1.1.	RS-485 Connection Requirements.....	3
2.1.2.	Troubleshooting Common RS-485 Problems .....	5
2.1.3.	10Base-T TCP/IP Ethernet Connection Requirements.....	6
2.2.	Setup Dual IQ Charger Synchronizing and Load Share .....	6
2.2.1.	REMOTE Charger Data Port Connection Requirements .....	6
2.2.2.	Troubleshooting Common REMOTE Charger Data Port Problems.....	9
2.3.	Setup Remote Temperature Sensor .....	9
2.3.1.	Remote Temperature Sensor Connection Requirements .....	9
2.3.2.	Troubleshooting Common Remote Temperature Sensor Problems.....	10
<b>3</b>	<b>Initial Setup to Communicate With Charger From PC Via USB Port</b> .....	11
3.1.	PC System Requirements .....	11
3.2.	Connect to USB Maintenance Port.....	11
3.3.	Install <i>SENS IQ &amp; CommsGenius Setup Utility</i> Software on Local PC and Verify Operation .	13
3.3.1.	Install software.....	13
3.3.2.	Verify Operation .....	13
3.3.3.	Troubleshooting USB and CommsGenius Communication .....	15
<b>4</b>	<b>USB Maintenance Port Operation using <i>SENS IQ &amp; CommsGenius Setup Utility</i></b> .....	16
4.1	<i>SENS IQ &amp; CommsGenius Setup Utility</i> Software Summary.....	16
4.2	<i>SENS IQ &amp; CommsGenius Setup Utility</i> Software Operations.....	17
4.2.1	File Menu .....	17
4.2.2	View Menu.....	18
4.2.3	Options Menu.....	20
4.2.4	Help Menu.....	20
<b>5</b>	<b>Dual IQ Charger Synchronizing and Load Share Operation</b> .....	21
5.1.	Charger Synchronization .....	21
5.2.	Load Share Operation .....	21
5.3.	Load Share Troubleshooting .....	21
<b>6</b>	<b>Remote Temperature Sensor Operation</b> .....	22
6.1	Sensor Placement.....	22
6.2	Electrical and Wiring Considerations.....	23
<b>7</b>	<b>Modbus Network Communications Operation</b> .....	23
7.1	Boolean Status (Binary Inputs), Modbus Function 0x02 .....	23
7.2	Boolean Read/Write Controls (Binary Outputs), Modbus Functions 0x01, 0x05, 0x0F.....	25
7.3	Numeric Read-Only Values, Modbus Function 0x04 .....	26
7.4	Read-Write Settings, Modbus Functions 0x03, 0x06, & 0x10.....	27
7.5	Communication Settings.....	28
7.6	Device Information Strings, Modbus Function 0x2B.....	30
7.7	IQ and CommsGenius Settings Limits .....	30
	<b>APPENDIX A: Modbus Address Reference by Function Type</b> .....	32
	<b>APPENDIX B: IQ Charger Voltage Setting Interlocks</b> .....	35
	<b>APPENDIX C: CommsGenius System Diagram</b> .....	38

**LIST OF FIGURES**

---

Figure 1: CommsGenius System Diagram.....	1
Figure 2: CommsGenius Connections Summary (customer connections indicated in bold).....	3
Figure 3: RS-485 Connection Diagram .....	4
Figure 4: RS-485 Connector .....	5
Figure 5: 10Base-T TCP/IP Ethernet Connection Diagram.....	6
Figure 6: 10Base-T TCP/IP Ethernet Connection.....	6
Figure 7: Load Share Connection Diagram .....	7
Figure 8: REMOTE Charger Data Cable Connection at CommsGenius .....	7
Figure 9: REMOTE Charger Port .....	8
Figure 10: REMOTE Charger Data Cable Connection at REMOTE Charger .....	8
Figure 11: REMOTE Charger Data Cable Routing .....	9
Figure 12: Remote Temperature Sensor Connection Diagram .....	9
Figure 13: Remote Temperature Sensor Socket and Cable Clips .....	10
Figure 14: USB Connection Diagram.....	11
Figure 15: USB Port.....	12
Figure 16: Select Software Connection Mode .....	14
Figure 17: Connect Software to CommsGenius .....	15
Figure 18: Main Software Window .....	15
Figure 19: CommsGenius Board LED.....	16
Figure 20: Example Software Active Windows.....	18

## 1 CommsGenius Description and Function Summary

The CommsGenius is an accessory module located inside a SENS EnerGenius IQ battery charger. The two primary functions are data communications and synchronizing of the operating modes of two digitally controlled IQ chargers including forced load sharing. Including the CommsGenius in an EnerGenius IQ battery charger provides the ability to monitor and/or configure the battery charger remotely using either serial or Ethernet connections.

**Figure 1: CommsGenius System Diagram**

CommsGenius in Single and Dual IQ Configurations

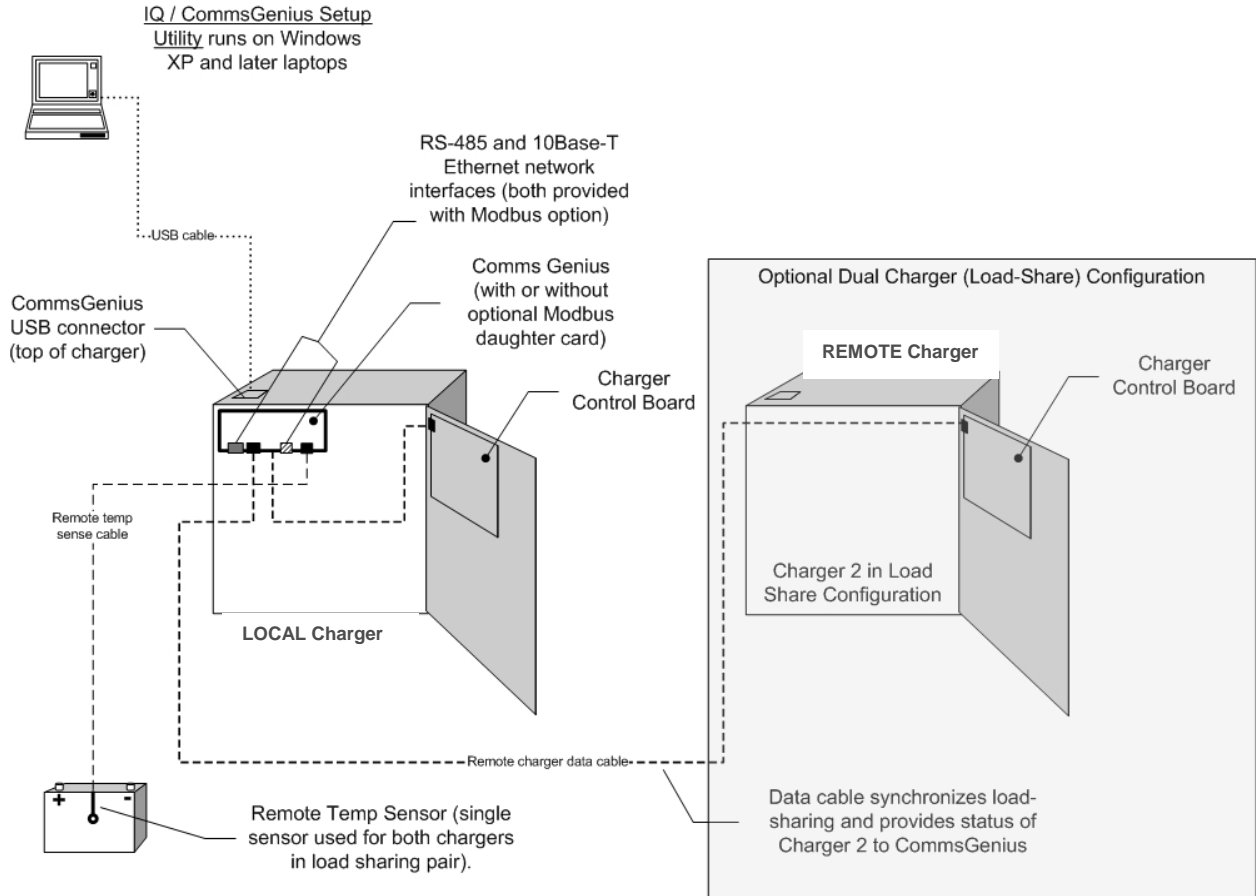

The CommsGenius is installed at the factory or can be added to IQ chargers in the field. Contact your charger supplier or SENS to determine if your charger qualifies as CommsGenius ready.

### 1.1 Data Communications Function

CommsGenius enables two modes of communication with the IQ charger: remote via Modbus or local via the USB maintenance port. Each communication method allows the user to adjust charger operating modes, view system settings, and adjust system settings.

#### 1.1.1 USB Maintenance Port – Local Communication

The USB maintenance port enables users to configure an IQ charger from a PC-based program called *SENS IQ & CommsGenius Setup Utility*. *SENS IQ & CommsGenius Setup*

*Utility* also enables fast and accurate execution of settings stored ahead of time, as might be required to accurately change a fleet of chargers.

This manual describes operation over the USB maintenance port in detail using the *SENS IQ & CommsGenius Setup Utility*. With a few exceptions noted in the Modbus section all information and commands available via the USB maintenance port are available over Modbus. Operation of the Modbus master HMI (Human Machine Interface) is outside the scope of this manual.

#### 1.1.2 Modbus Network – Remote Communication

If the remote communications processor daughter board was ordered, Modbus data communications will be available over either RS-485 (pluggable terminal block) or 10Base-T TCP/IP Ethernet (RJ-45 connector). Each of these ports is user configurable in the *SENS IQ & CommsGenius Setup Utility* program. The communications processor daughter board is installed at the factory or it can be added in the field to an existing CommsGenius. The *SENS IQ & CommsGenius Setup Utility* program is used to initially configure Modbus settings.

#### 1.2 Dual IQ Charger Synchronizing and Load Share Functions

The CommsGenius provides a central point of communication with both chargers of a redundant charger system, and ensures that chargers behave in an identical manner. This enables:

- A common source of battery temperature data for charge voltage temperature compensation ("remote temperature sense")
- Forced load sharing
- Harmonized operation of chargers while in modes other than float charge, such as equalize charge or battery check

Only one IQ charger in a two charger redundant system requires a CommsGenius accessory module for charger synchronization and load sharing.

#### 1.3 CommsGenius On-Board Battery

The CommsGenius includes an on-board coin cell battery to ensure data and time retention regardless of charger operation. Use Modbus address 0x0001 to determine if the battery needs to be replaced. This battery type is identical to that typically supplied in PCs to support the real time clock.

*Note: Battery contains Perchlorate material – special handling may apply. See [www.dtsc.ca.gov/hazardouswaste/perchlorate](http://www.dtsc.ca.gov/hazardouswaste/perchlorate).*

The battery may be replaced by trained service personnel only. Disconnect both AC and DC power sources before attempting to service the battery. Replace the battery with only a lithium CR2032 rated for use at 70°C or higher.

## 2 Initial Hardware Setup

### 2.1. Setup CommsGenius Network Connections

Connect hardware as described and shown below. See Section 3 for instructions on configuring hardware connections using *SENS IQ & CommsGenius Setup Utility* software. See Appendix C for System Diagram.

**Figure 2: CommsGenius Connections Summary** (customer connections indicated in bold)

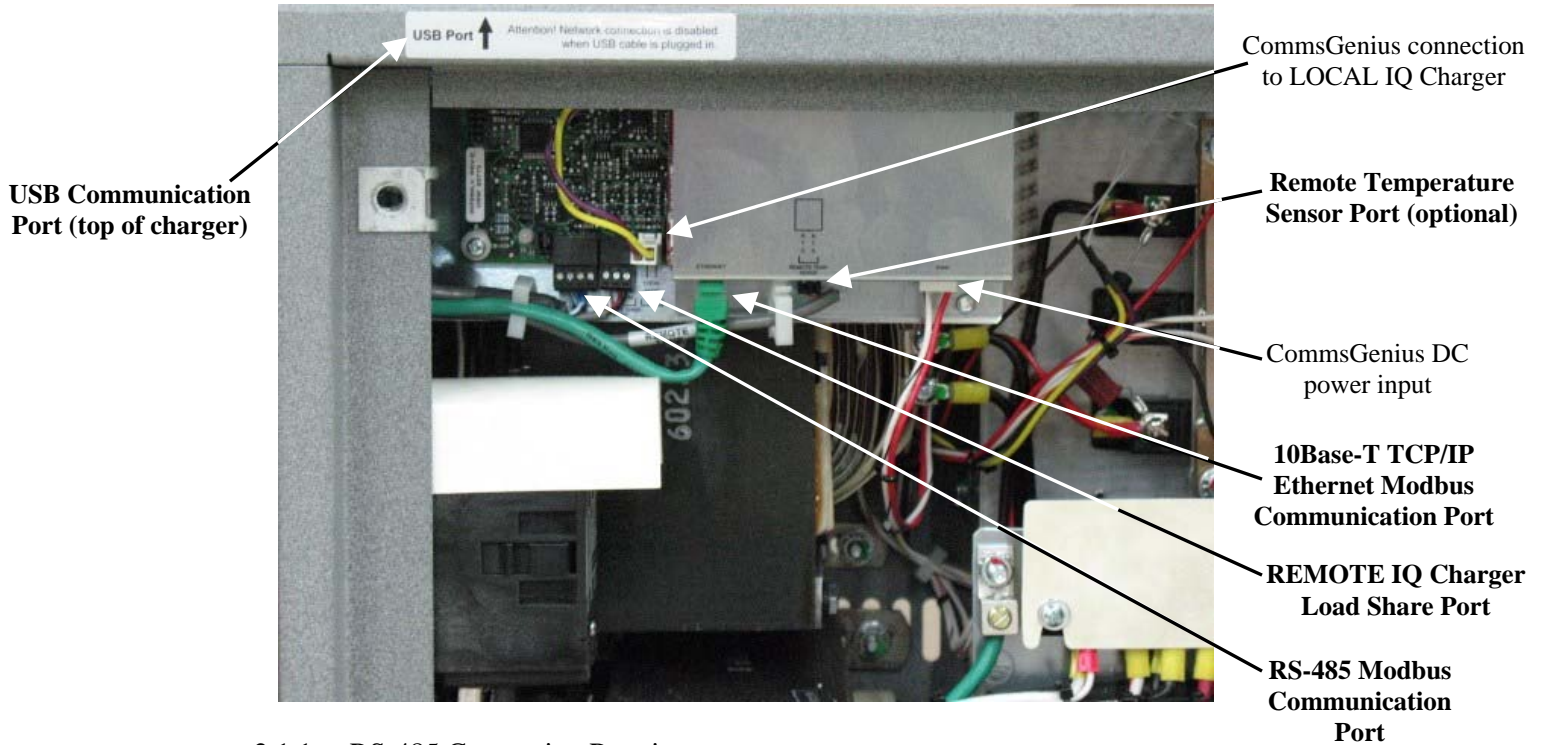

#### 2.1.1. RS-485 Connection Requirements

The RS-485 network cabling shall be installed as described in *Modbus over serial line specification and implementation guide V1.02*, published by Modbus-IDA (<http://www.Modbus-IDA.org>).

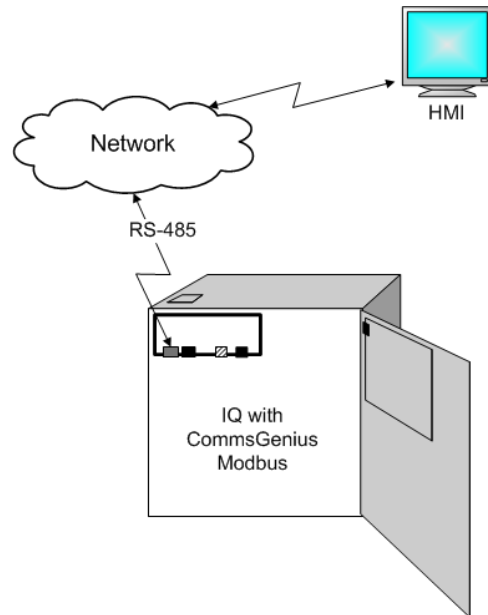
**Figure 3: RS-485 Connection Diagram**

Pay special attention to these requirements:

- Bus loading shall be not more than 32 devices on a bus, unless RS-485 repeaters break the bus into segments with no more than 32 device loads each. The bus master and bus repeater(s) count against the 32-device limit (See Physical Layer - Multipoint System requirements section in Modbus-IDA specification).
- Maximum bus length not to exceed 1000m (3000 ft) at 9600 Baud, reduced appropriately for faster data rates (See Physical Layer - Multipoint System requirements section in Modbus-IDA specification)
- Stubs ("derivation cables") shall not exceed 40m (120 ft) total for all passive taps attached to the bus, and not more than 20m (60 ft) at any one tap (See Physical Layer - Multipoint System requirements section in Modbus-IDA specification)
- Longer stubs require the use of "active taps" (See Physical Layer - Electrical Interfaces section in Modbus-IDA specification)
- The "COM" line (signal reference) must be connected to all devices on the bus. COM shall be tied to chassis ("earth", "protective ground") at *exactly one point*, preferably at the bus master (See Physical Layer - Multipoint System requirements section in Modbus-IDA specification)
- Cable terminations are applied only at the ends of the bus (See Physical Layer - Multipoint System requirements section in Modbus-IDA specification)
- SENS IQ and CommsGenius do not require bus polarization (See Physical Layer - Multipoint System requirements section in Modbus-IDA specification)
- Cables must have shielded twisted pair construction, with nominal impedance between 100Ω and 150Ω (See Physical Layer – Cables section in Modbus-IDA specification)
- Cables must be rated for use at 70°C or higher.
- Cable enters the charger at the opening at the top left side of the chassis. Keep signal cables away from the AC and DC power wiring!
- Attach the RS-485 cable to the four-position connector provided with the CommsGenius communications board. COM is pin 1 (left), +D1 (A) is pin 2, -

D0 (B) is pin 3, and protective ground (chassis) is pin 4 (right). See Modbus-IDA specification for further connection definitions and explanation.

**Figure 4: RS-485 Connector**

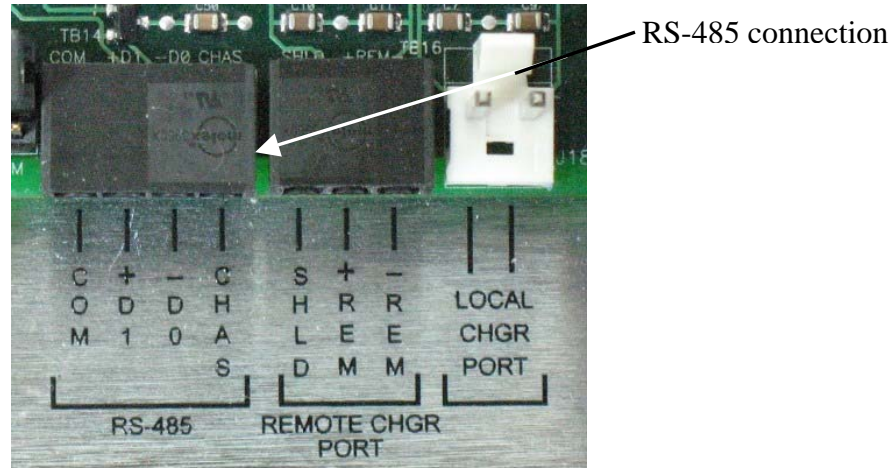

- The common (signal reference) line may either be connected using the cable shield (all devices connect COM to the shield, only MASTER connects shield to protective ground), or connected using a third wire in the shielded cable (all devices connect COM to the third wire, all devices connect the shield to protective ground, only MASTER connects COM to protective ground). *SENS products are compatible with either convention for shield connections, provided use of the cable shield is consistent throughout the RS-485 bus. Mixing shield connection conventions within the same bus is not acceptable; this causes increased system noise and data errors.*

#### 2.1.2. Troubleshooting Common RS-485 Problems

- Data rate too fast for the bus cable in use. Lower quality cables have higher signal loss, reducing the maximum possible length.
- Incorrect baud rate settings in one or more devices
- Incorrect parity and stop-bit settings in one or more devices
- Data cables exposed to excessive noise and transients. Route data cables as far away from power conductors as practical. Data cables run outdoors or for long distances (more than 10m between bus devices) should be equipped with appropriate transient protection devices.
- Reversed polarity on one or more devices. All -D0 (B) signals must be on the same wire, all +D1 (A) signals must be on the same wire, and all COM signals must be on the same wire.
- Missing COM connection on one or more devices
- Improper termination: termination *must* be applied only at the ends of the bus, the inputs and outputs of RS-485 *repeaters*, and at both ends of *active* bus tap cables. Termination *must not* be enabled for devices inside the bus, including devices on *passive taps* (stubs).
- Connecting COM to protective ground at more than one point. This connection shall be made at one point, and only one point, preferably at the *bus master*.
- Shields connected at only one end. "Ground loop" currents should be avoided by connecting the shield to either COM or CHASSIS in all slave devices, taps, and

repeaters. The only place where the shield may connect to both circuits is the single-point ground (at the bus master). If the shield is connected to CHASSIS in all slave devices, then a separate conductor for COM must be provided in the shielded cable.

2.1.3. 10Base-T TCP/IP Ethernet Connection Requirements

The 10Base-T TCP/IP Ethernet connection is a standard 10-Base-T or 100-Base-T connection. Connect to the RJ-45 connector using a Cat5 or better cable.

*WARNING: The 10Base-T TCP/IP Ethernet connection is **not for telephone use**. High ringing voltages on telephone wiring may damage the network card.*

**Figure 5: 10Base-T TCP/IP Ethernet Connection Diagram**

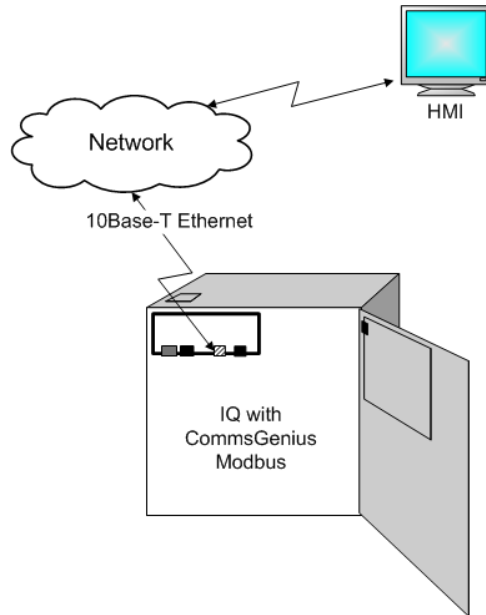

**Figure 6: 10Base-T TCP/IP Ethernet Connection**

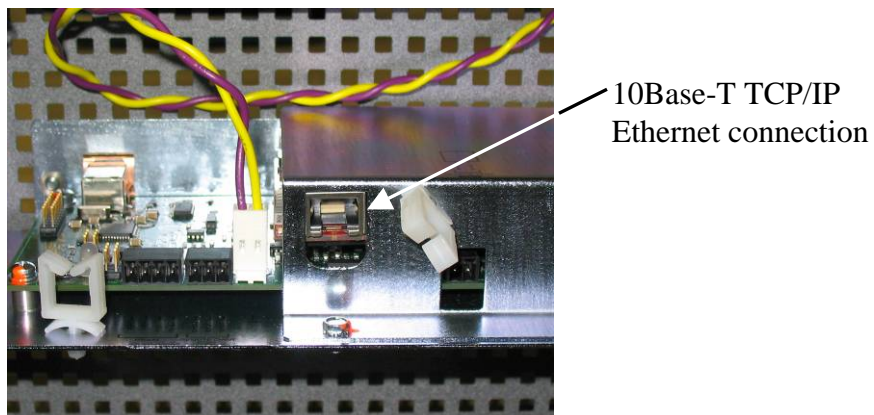

2.2. Setup Dual IQ Charger Synchronizing and Load Share

2.2.1. REMOTE Charger Data Port Connection Requirements

Use the provided REMOTE Charger Data cable to connect the REMOTE charger for dual charger systems. The cable enters both chargers at the opening at the top left side of the chassis. *Keep signal cables away from the AC and DC power wiring!*

**Figure 7: Load Share Connection Diagram**

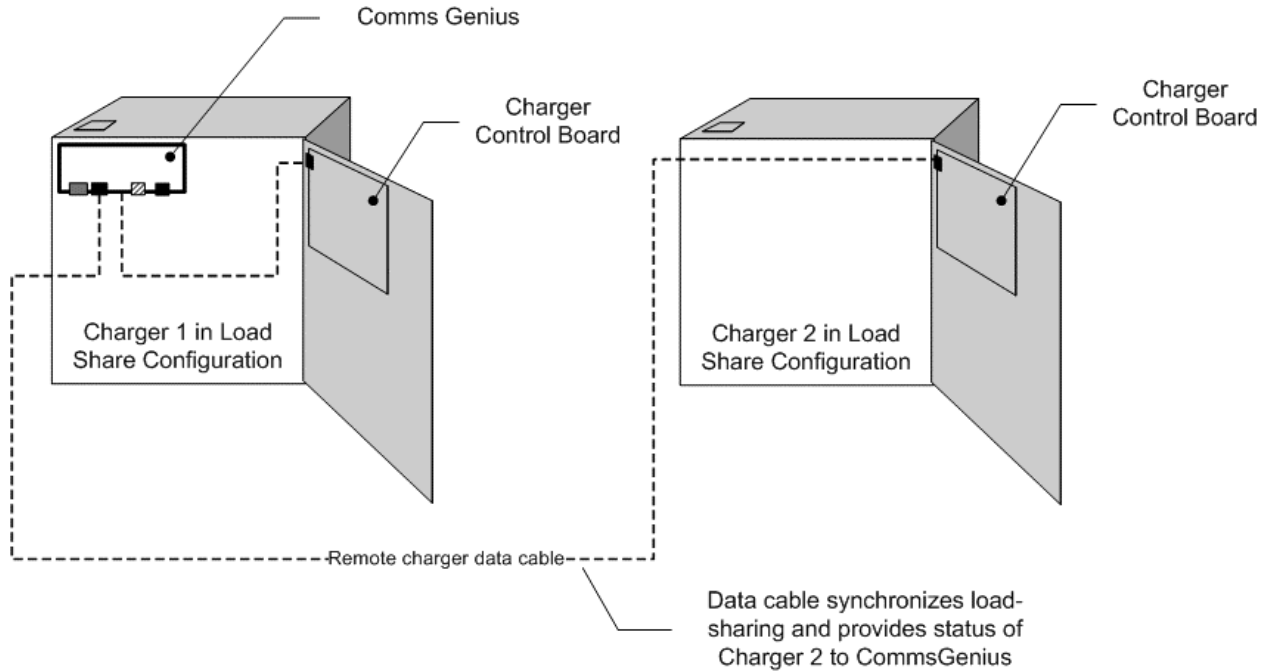

2.2.1.1. Connection at the CommsGenius

- Attach the sensor wires to the three-position connector provided with the CommsGenius communications board. Be sure the wire order in the connector (shield at top, then red, then black) is correct per the orientation shown in Figure 1 (wires on left, with screws facing the installer).

**Figure 8: REMOTE Charger Data Cable Connection at CommsGenius**

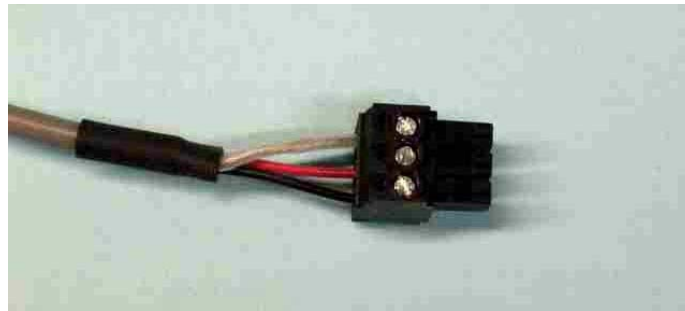

- The three-position connector (with wires attached) then attaches to the REMOTE Charger Port on the CommsGenius.

**Figure 9: REMOTE Charger Port**

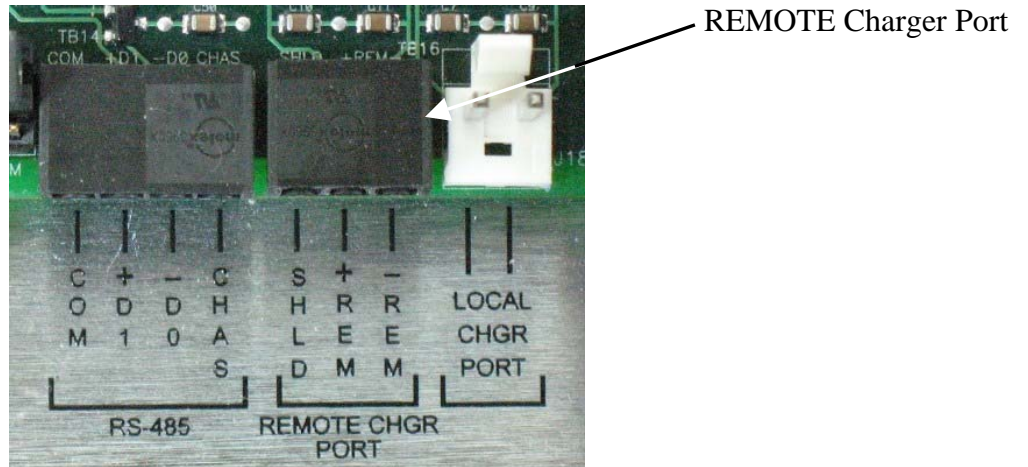

- Use the cable clips on the CommsGenius bracket to support the cable and connector.

2.2.1.2. Connection at the REMOTE Charger

- The other end of the cable attaches to the upper terminal block (TB2) on the control board of the second charger.
- Route the wiring through the cable clip at the upper right corner of the charger's control board. This relieves stress at the terminal connections.
- Avoid excess slack in the wiring. Excess wire should be neatly bundled and tied near the cable entrance, so it cannot contact any live or hot parts.
- Connect the cable shield to terminal #1 (SHIELD), the red wire to terminal #2 (+LOOP), and the black wire to terminal #3 (-LOOP).

**Figure 10: REMOTE Charger Data Cable Connection at REMOTE Charger**

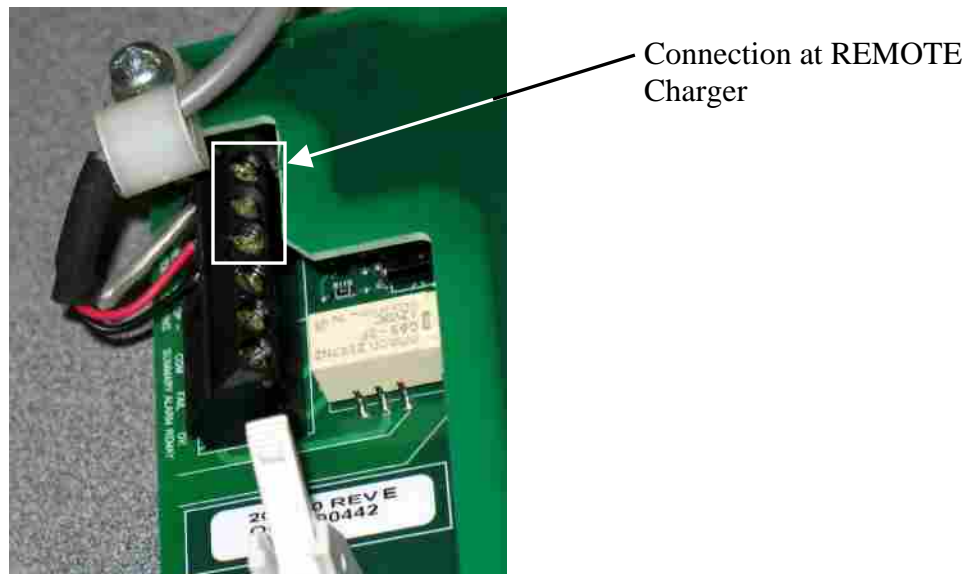

- Route the wiring through the cable clips behind and under the top door frame of the second charger. This holds the wiring away from hot and live parts inside the charger, and prevents pinching the cable when the door is closed.

**Figure 11: REMOTE Charger Data Cable Routing**



2.2.2. Troubleshooting Common REMOTE Charger Data Port Problems

- Reversed polarity at the charger control board (verify wiring by color code).
- Connecting to the wrong terminal block on the charger control board. The lower terminal block (TB3) is for the summary alarm relay, not the data port cable.
- Connecting the three-pin data port connector to the four-pin RS-485 socket on the CommsGenius communications board.

2.3. Setup Remote Temperature Sensor

**Figure 12: Remote Temperature Sensor Connection Diagram**

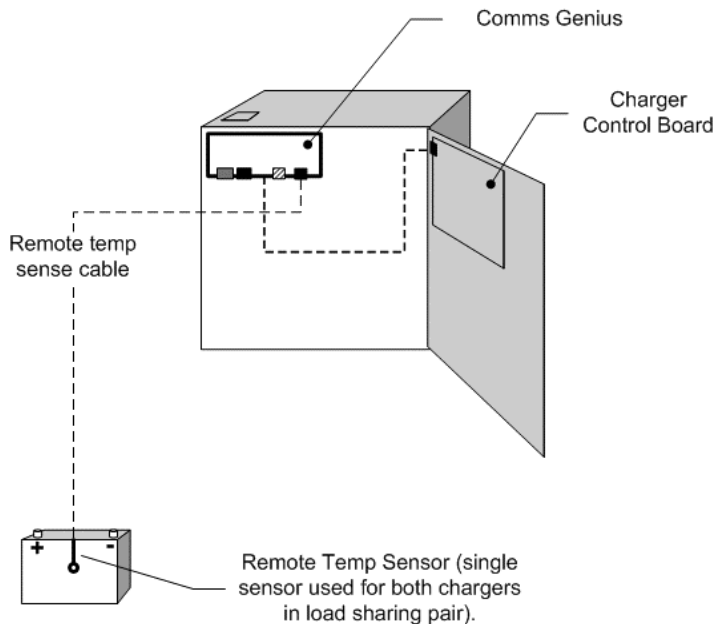

2.3.1. Remote Temperature Sensor Connection Requirements

- Use the provided temperature sensor and cable.
- Locate the sensor where it will be exposed to the same temperature as the batteries being charged, but *not* directly attached to hazardous live parts. See the “How to

Install a Remote Temperature Sensor” insert provided with the remote temperature sensor kit for detailed instructions on sensor placement.

- Attach the sensor to the two-position connector provided with the CommsGenius communications board. The temperature sensor is not polarity-sensitive.
- Cables enters the charger at the opening at the top left side of the chassis. Keep signal cables away from the AC and DC power wiring!
- The two-position connector attaches to the mating socket on the CommsGenius communications board. Use the cable clips on the CommsGenius communications board bracket to support the cable and connector.

**Figure 13: Remote Temperature Sensor Socket and Cable Clips**

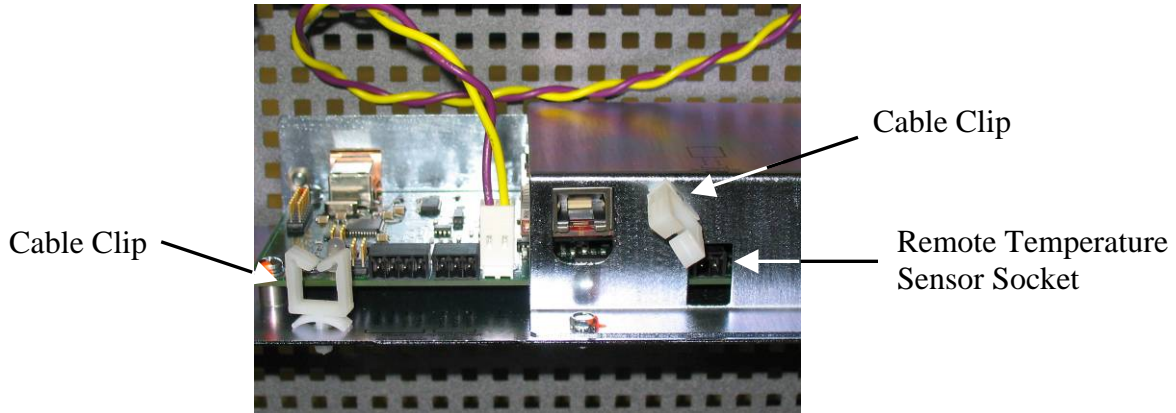

2.3.2. Troubleshooting Common Remote Temperature Sensor Problems

- Connecting the two-pin temperature sensor connector to the three-pin data port connector or to the four-pin RS-485 socket on the CommsGenius communications board.
- Temperature sensor installed where air temperature differs from battery temperature, such as close to heat-producing equipment. Affix the sensor to the battery as specified in Section 6.

### 3 Initial Setup to Communicate With Charger From PC Via USB Port

#### 3.1. PC System Requirements

Setting up a CommsGenius requires a PC. The CommsGenius does not include DIP switches or any other means of manual configuration.

**Figure 14: USB Connection Diagram**

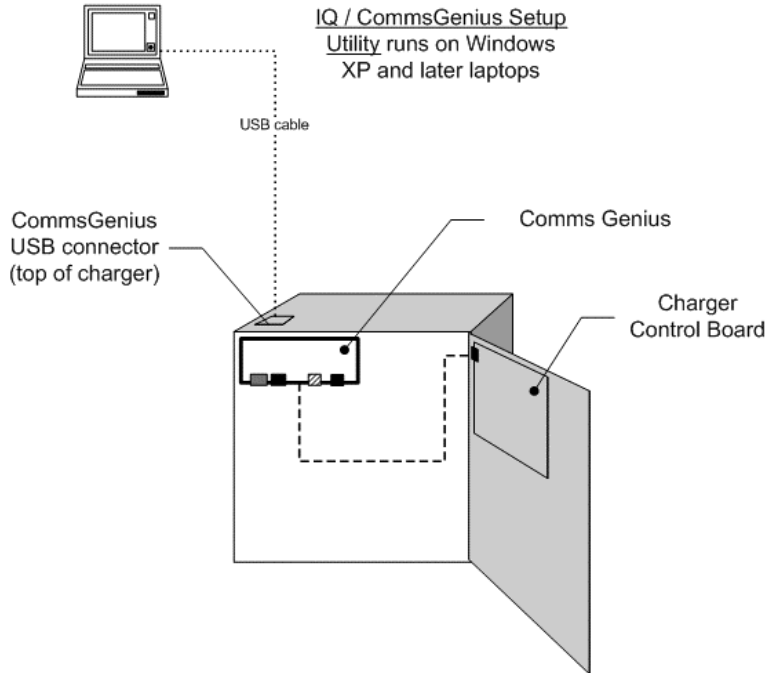

- CPU: 32-bit 600 Mhz minimum, 1 Ghz recommended
- Operating system: Microsoft Windows 2000® acceptable, Windows XP® or Vista® recommended
- System RAM: 512 MB minimum, 1 GB recommended
- Disk space: 285 MB
- Display resolution: 1024 x 768 minimum, 1280 x 1024 recommended
- USB 2.0 host port capable of full power operation (500mA), cable up to 4.5m (15 feet) long, standard size type "B" connector. A 2m (6 foot) cable is included with charger.

#### 3.2. Connect to USB Maintenance Port

Connect the USB maintenance port to the PC via a USB 2.0 interface. The USB cable must have a standard size "type B" plug for the maintenance port, and may be up to 4.5m (15 feet) long. The USB cable should not be extended beyond this length. The IQ charger USB maintenance port is a "plug-and-play" USB serial port that requires a driver to be installed on the PC before it can be used. Install the driver by following the instructions in Section 3.3 or the README file provided on the accompanying software CD. Detailed instructions on driver installation are provided at <http://www.ftdichip.com/Documents/InstallGuides.htm>. To view instructions, select the Installation Guide appropriate for your PC operating system.

**Figure 15: USB Port**

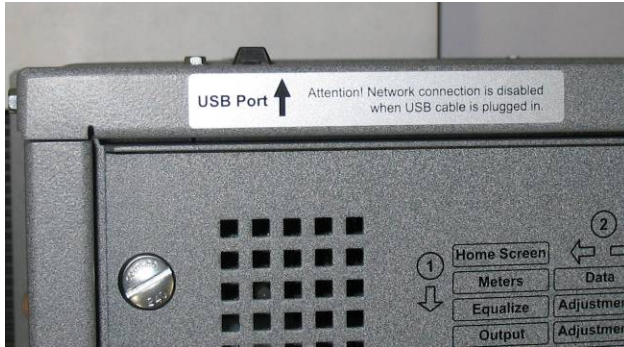

The communications board will be powered-on and operate whenever it is connected to a USB host, whether or not the charger is operating. This permits using the maintenance port to configure communications settings before the final charger installation. However, it is not possible to communicate with the charger via the CommsGenius or to adjust any charger settings unless the charger is operating from an AC or DC power source.

USB version 2.0 is required for proper operation. See the following steps to determine if the connected PC has version 2.0:

- Navigate as follows:
  - Right-click **My Computer**
  - Click on **Properties**
  - Click on the **Hardware** tab
  - Click on the **Device Manager** button
  - Scroll down as needed until you see **Universal Serial Bus Controllers**
  - Expand that by clicking on the boxed plus sign in front of **Universal Serial Bus Controllers**
  
- View similar to following:

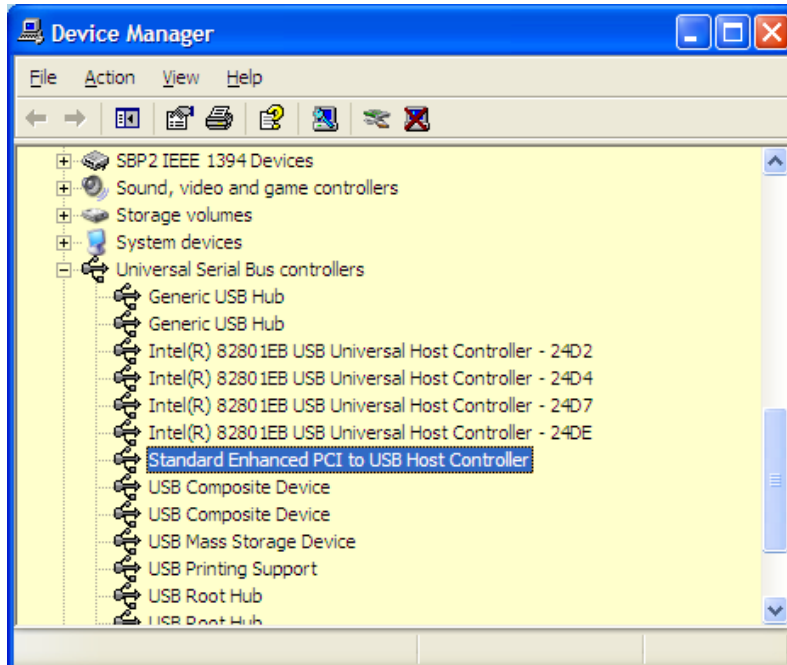

- Note the highlighted line: "Standard Enhanced PCI to USB Host Controller". While the exact text may vary, the presence of the word "Enhanced" indicates USB 2.0. If "Enhanced" is not included, the port is USB 1.x only. Note that even with the word "Enhanced" some machines may have a mixture of 1.1 and 2.0 ports. Consult the PC Manual to confirm which ports are 1.1 and 2.0.

### 3.3. Install SENS IQ & CommsGenius Setup Utility Software on Local PC and Verify Operation

#### 3.3.1. Install software

IMPORTANT: These steps MUST be completed in order from 1 to 6

- Uninstall any previous installations of the *SENS IQ & CommsGenius Setup Utility* using Microsoft "Add or Remove Programs" on the Control Panel
- Insert the software installation CD provided with the CommsGenius accessory module and open browser window to view CD files
- Install the USB driver provided by double-clicking on the *FTDI USB DRIVER AUTO Install (CDM 2.04.16).exe* file  
*Note: A DOS window will appear with "Installing driver...", if the window exits with no errors, the installation was successful*
- Connect the USB cable to the PC (USB Version 2.0 only) and to the charger (left-side of the top cover)  
*Note: Windows will communicate "Found New Hardware"; wait until you see "Your new hardware is installed and ready to use"*
- Install the Microsoft .NET Framework Version 2.0 provided by double-clicking on the *dotnetfx.exe* file. Follow instructions to complete setup.  
*Note: If a .NET compatibility error occurs, you have a newer version of .NET and can still proceed*
- Install the *SENS IQ & CommsGenius Setup Utility* by double-clicking the *SENS IQ & CommsGenius Setup Utility.msi* file. Follow instructions to complete setup.

#### 3.3.2. Verify Operation

Open the *SENS IQ & CommsGenius Setup Utility* by selecting *SENS IQ & CommsGenius Setup Utility* under the *SENS* folder found via the PC *Start* menu.

Once open, select the desired mode or choose to update CommsGenius firmware under the *Options* pull-down menu as shown below.

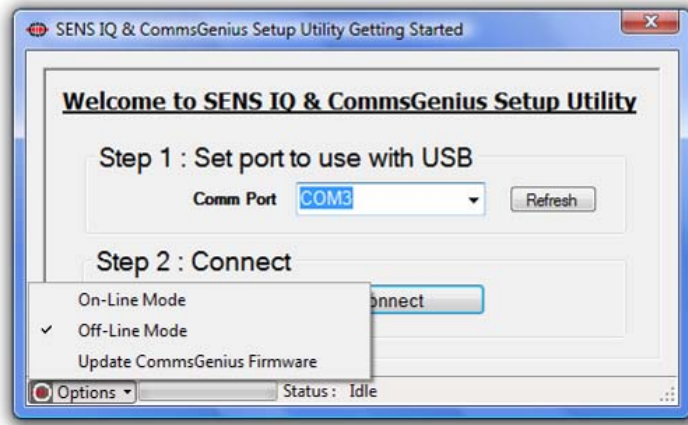
**Figure 16: Select Software Connection Mode**

- On-Line Mode – normal operating mode used to view and adjust connected CommsGenius settings.  
*Note: While in On-line mode, if the USB cable is disconnected and a read is attempted in the SENS IQ & CommsGenius Setup Utility, a fatal error will be displayed and the utility will close.*
- Off-Line Mode – use when not connected to a CommsGenius or when values are to be saved to a file and not to the charger via the CommsGenius. Adjust and save values to a file for future upload to a CommsGenius.
- Update CommsGenius Firmware - select to update CommsGenius firmware. Once selected, open the appropriate .scg firmware file and wait for firmware update to complete. The status at the bottom of the window will show "Firmware Update Successful" when the update has completed properly.  
*Note: .scg firmware files should not be confused with .cgs data files created using the SENS IQ & CommsGenius Setup Utility*

Next, select the serial port used to connect the PC to the CommsGenius from the drop-down selection under *Step 1*. If it is unclear which Comm Port to select, see the following instructions to determine the proper Comm Port:

- Plug in the USB cable prior to opening the *SENS IQ & CommsGenius Setup Utility*
- View the Comm Port options in the drop-down selection
- Disconnect the USB cable and refresh the software program. The Comm Port no longer present is the correct selection.
- Reconnect the USB cable and refresh to make the correct selection.

Press the *Connect* button under *Step 2* to connect the *SENS IQ & CommsGenius Setup Utility* to the CommsGenius, or to fully open the software when in *Off-Line Mode*.

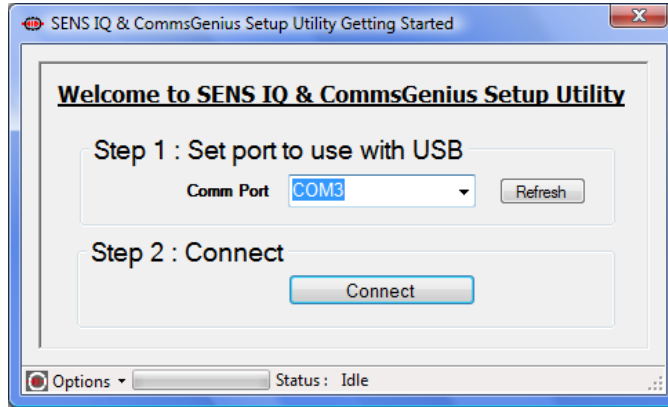
**Figure 17: Connect Software to CommsGenius**

Upon successful connection, the software will open and display a quick start guide as well as a blank window with menu options as shown below. See Section 4 for software instructions and details.

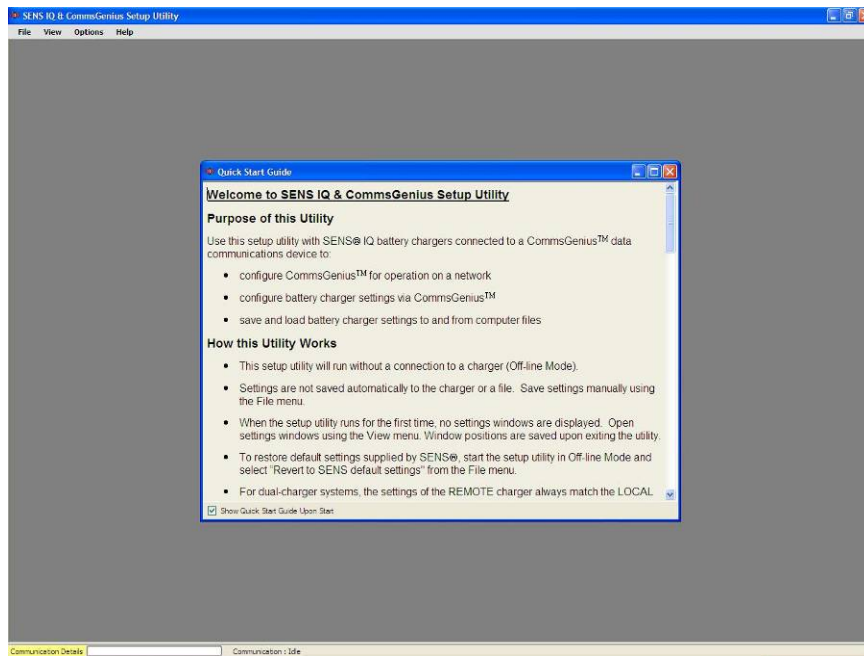
**Figure 18: Main Software Window**

### 3.3.3. Troubleshooting USB and CommsGenius Communication

If the *SENS IQ & CommsGenius Setup Utility* will not connect with the CommsGenius:

- Ensure the proper Comm Port is selected. See previous section for instructions on Comm Port selection.
- Verify the USB cable is properly connected to the PC and IQ charger
- Verify the CommsGenius is powered on and connected to the IQ charger. When connected, the LED on the CommsGenius board will be lighted. This LED will also blink upon clicking the "Connect" button on the *Getting Started* window.

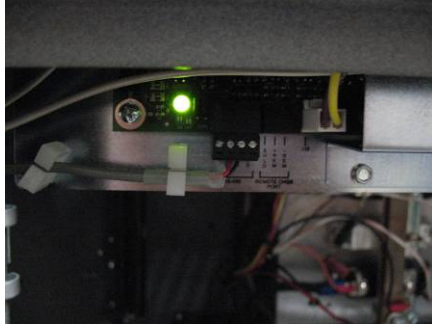
**Figure 19: CommsGenius Board LED**

#### 4 USB Maintenance Port Operation using *SENS IQ & CommsGenius Setup Utility*

The USB maintenance port enables users to configure an IQ charger using the PC-based *SENS IQ & CommsGenius Setup Utility* (see previous sections for hardware and software installation instructions). With a few exceptions, all functions available via the IQ charger front panel display are available using the *SENS IQ & CommsGenius Setup Utility* software.

**IMPORTANT:** Plugging a USB cable into the charger's USB maintenance port interrupts network communications. *If your system is in active network use make sure you alert your network operator that you will be taking the charger offline by using USB communications.* Network communications is automatically restored when you remove the USB cable from the charger's USB port.

*Note: While in On-line mode, if the USB cable is disconnected and a read is attempted in the SENS IQ & CommsGenius Setup Utility, a fatal error will be displayed and the utility will close.*

##### 4.1 *SENS IQ & CommsGenius Setup Utility* Software Summary

The *SENS IQ & CommsGenius Setup Utility* is arranged in windows that generally correlate to the charger's front panel menu selections, as shown in the table below:

<b>Task</b>	<b>Charger Front Panel</b>	<b><i>SENS IQ &amp; CommsGenius Setup Utility</i> Window on PC (accessed via View menu)</b>
Read meters	Read front panel LCD	Meters
Adjust charger operating modes	Charge mode key	Operating Mode
View/adjust equalize settings	Equalize settings menu	System Equalize
View/adjust charger output settings	Output settings menu	System Output
View alarm status	Front panel LED, LCD	Alarm Status
Adjust alarm settings	Alarm settings menu	Alarm Status
Perform manual battery check	Battery check key	Operating Mode

Adjust battery check settings	Battery check menu	Battery Check
Adjust temperature compensation settings	Unit setup menu	Temp Comp System
View charger configuration	View unit info menu	Charger Configuration
Adjust number of battery cells	Unit setup menu	Charger Configuration

4.2 SENS IQ & CommsGenius Setup Utility Software Operations

*Note: The settings described below are limited by the charger’s control laws, and are explained in the EnerGenius IQ user manual. In redundant charger systems the settings made are automatically applied to both chargers, and override existing settings.*

4.2.1 File Menu

Access file and save options by selecting the **File** pull-down menu.

4.2.1.1 Open Settings File...

Load/populate the *SENS IQ & CommsGenius Setup Utility* with settings from a file stored on the PC.

4.2.1.2 Open Charger(s) Settings via CommsGenius

Load/ populate the *SENS IQ & CommsGenius Setup Utility* with settings stored on the CommsGenius and its host IQ charger.

4.2.1.3 Save Settings File

Save settings displayed in the *SENS IQ & CommsGenius Setup Utility* to a file for later use. Saved CommsGenius Settings Files will have a .cgs extension.

*Note: .cgs files created using the SENS IQ & CommsGenius Setup Utility should not be confused with .scg CommsGenius firmware files*

4.2.1.4 Save Settings File As...

Save settings (select save directory) displayed in the *SENS IQ & CommsGenius Setup Utility* to a file for later use. Saved CommsGenius Settings Files will have a .cgs extension.

*Note: .cgs files created using the SENS IQ & CommsGenius Setup Utility should not be confused with .scg CommsGenius firmware files*

4.2.1.5 Save Settings to Charger(s) via CommsGenius

Execute settings made and displayed in the *SENS IQ & CommsGenius Setup Utility* to the CommsGenius.

**IMPORTANT:** *No settings changes made to the SENS IQ & CommsGenius Setup Utility are written to the CommsGenius or host IQ charger until this menu selection is made.*

There is no “undo” command other than restoring factory defaults, so double-check values before saving settings to charger.

4.2.1.6 Revert to SENS Default Settings

Load/populate the *SENS IQ & CommsGenius Setup Utility* with SENS factory default charger settings when in Off-line mode only (feature not active in On-line mode).

Select appropriate battery type to ensure proper settings.

4.2.1.7 Exit  
Exit the *SENS IQ & CommsGenius Setup Utility*.

4.2.2 View Menu  
Access each window of the *SENS IQ & CommsGenius Setup Utility* by selecting it from the **View** pull-down menu. Each window remains active in the program as long as it remains selected in the **View** menu. A check mark by each option in the menu list indicates the window is displayed. Remove a window by deselecting it from the **View** menu or closing the window. The window arrangement is automatically saved upon exit.

**Figure 20: Example Software Active Windows**

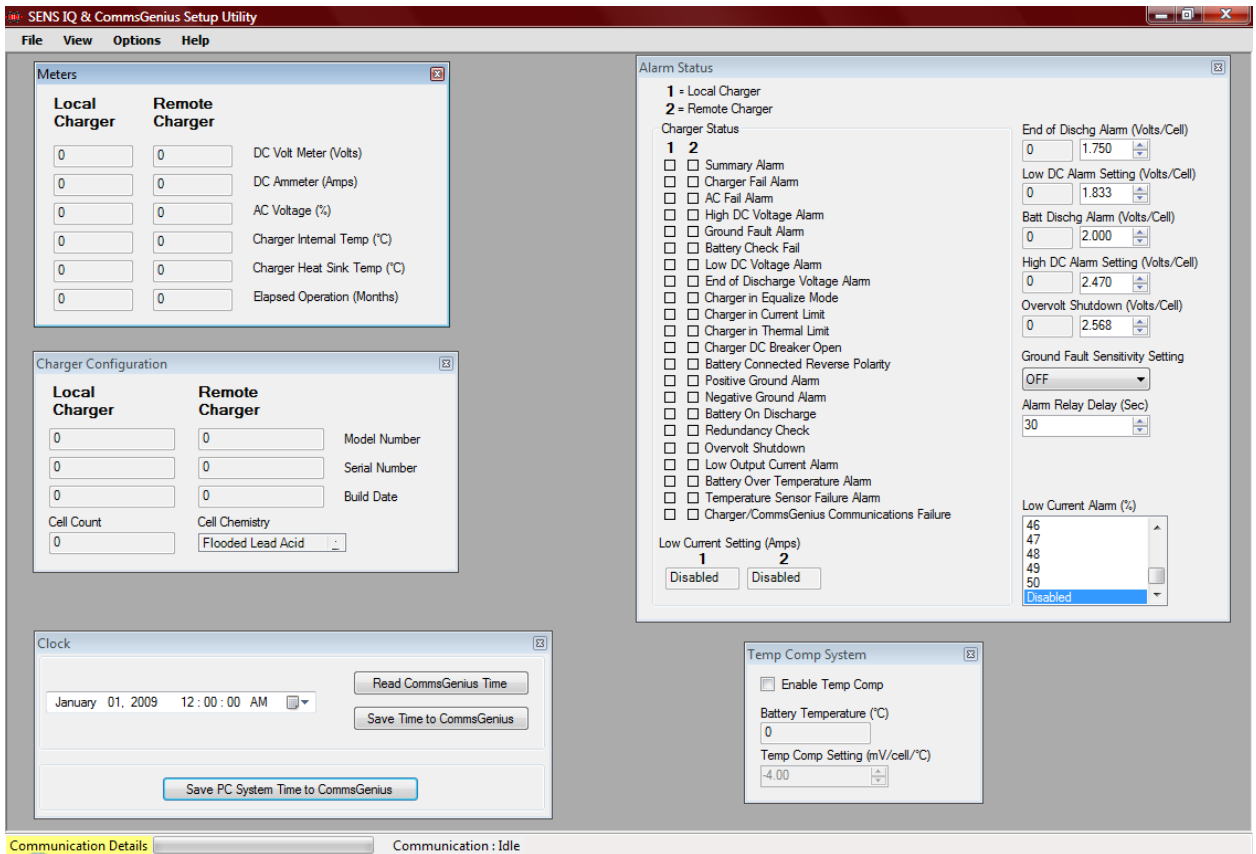

4.2.2.1 Read Only Settings  
Open windows to view charger settings. No adjustments are allowed to these settings.

4.2.2.1.1 Meters  
View charger voltage, amperes, temperature and elapsed operation time.  
*Note: Elapsed Operation months in the Meters window are 4week/28day months.*

4.2.2.1.2 Charger Configuration  
View model number, serial number, build date, battery cell count, and battery cell chemistry.

#### 4.2.2.2 Real Time Controls

Open a window to adjust charger controls in real-time. In contrast to all other windows, any changes requested from this window are immediately executed by the charger. No other windows are active while this window is open. You must close the Real Time Controls window to make changes to any other menu item.

##### 4.2.2.2.1 Operating Mode

Set and view Float, Equalize, or Auto output modes, Battery Check mode and view Equalize time remaining and time elapsed. Select the desired mode to engage that mode at the charger.

#### 4.2.2.3 Settings

Open windows containing settings that may be viewed, adjusted, and saved to the CommsGenius or a file using the options provided under the **File** menu.

##### 4.2.2.3.1 System Equalize

View and adjust equalize operation values.

##### 4.2.2.3.2 System Output

View and adjust output voltages and current limit operation.

##### 4.2.2.3.3 Alarm Status

View active alarms, which are indicated by a check mark next to each alarm. Also view and adjust alarm settings. In a redundant charger system the CommsGenius forces both chargers' alarm setpoints to identical values, but displays alarm states independently.

*Note: When there is a communications failure between the IQ charger and the CommsGenius, the Charger/CommsGenius Communications Failure alarm is the only alarm that will show RED. The status of the other alarms will show GREY and may or may not be valid due to the lack of communication with the charger.*

##### 4.2.2.3.4 Battery Check

Enable and configure Battery Check operation.

##### 4.2.2.3.5 Temp Comp System

Enable and configure Temperature Compensation operation.

##### 4.2.2.3.6 Communication

Enable and configure the preferred communication method. By factory default, CommsGenius enabled IQ chargers are configurable only via a direct USB cable connection. To enable an alternate network connection method, the user must first connect using the USB cable and then select either *Serial Modbus ASCII*, *Serial Modbus RTU*, or *Modbus TCP/IP*. The CommsGenius can only connect through one method at a time. The USB cable connection will always take priority and disable other connections.

All connections, except for a direct USB cable, are read-only by factory default for security reasons. See *Allow Network Access* under the **Options** menu for information on enabling network access.

##### 4.2.2.3.7 Clock

View and adjust date and time. Choose to read time from or save time to the connected CommsGenius. If *Use PC System Time* (under the **Options** menu) is active, then the *Clock* window values are ignored and the PC system time is used instead.

*Note: Be sure PC system time matches network time as networks may standardize on a time zone different from local time or may not adjust for daylight savings time.*

#### 4.2.3 Options Menu

Access options by selecting the **Options** pull-down menu. Select each option to activate. A check mark by each option in the menu list indicates the feature is active. Deactivate by deselecting each option from the **Options** menu.

##### 4.2.3.1 Dual Chargers

View the REMOTE charger of a redundant charger system when the CommsGenius is connected to both LOCAL and REMOTE chargers. LOCAL and REMOTE charger values will be displayed together in windows activated using the **View** pull-down menu.

*NOTE: Any changes to this setting will be ignored unless the user executes a "Save Settings to Charger(s) via CommsGenius" command. Even if the Utility shows it as enabled, the user must do an "Open Charger(s) Settings via CommsGenius" command and check to verify that the setting has been stored.*

##### 4.2.3.2 Allow Network Access

Enable ability to adjust all *SENS IQ & CommsGenius Setup Utility* settings via network communication, rather than only by the USB cable connection. By enabling network access the user assumes all liability with regards to security as described in the software end-user license agreement.

*NOTE: Any changes to this setting will be ignored unless the user executes a "Save Settings to Charger(s) via CommsGenius" command. Even if the Utility shows it as enabled, the user must do an "Open Charger(s) Settings via CommsGenius" command and check to verify that the setting has been stored.*

##### 4.2.3.3 Use PC System Time

Enable use of PC system time for CommsGenius time. When active, the PC system date and time are automatically used for the CommsGenius and values set in the *Clock* window (under the **View** menu) are ignored.

#### 4.2.4 Help Menu

Access help options by selecting the **Help** pull-down menu.

##### 4.2.4.1 Help File

View basic help and troubleshooting information.

##### 4.2.4.2 Quick Start Guide

View Quick Start Guide

##### 4.2.4.3 About

View *SENS IQ & CommsGenius Setup Utility* version and basic information.

##### 4.2.4.4 Reset Warnings

Re-enable any help/warning/tip boxes that were previously selected to not show again.

## 5 Dual IQ Charger Synchronizing and Load Share Operation

---

Load Sharing is an optional feature in which two chargers are electrically connected using a CommsGenius and the REMOTE Charger Data cable. Load sharing is intended to force two chargers to resolve close differences in output voltage settings to ensure the current load is shared equally. Because the two chargers are connected to one set of batteries, load share operation works best if accompanied by a Remote Temperature Sensor (see Section 6).

Normally only one IQ charger from a two charger redundant system will include a CommsGenius accessory module for charger synchronization and load sharing. See Section 2 for installation instructions. It is possible, but not recommended, for each of a redundant pair of chargers to use its own CommsGenius. When this is the choice, the inter-charger communication feature of the CommsGenius cannot be used. This means that the automatic synchronization of operating values and modes will not occur. Instead of a “redundant charger system” the chargers will operate as fully independent chargers.

The IQ charger that physically hosts the CommsGenius accessory module is called the LOCAL charger. The IQ charger connected to the host IQ’s CommsGenius via the REMOTE load share port is called the REMOTE charger. See Appendix C for System Diagram.

### 5.1. Charger Synchronization

After some moments, up to a minute, after connecting the REMOTE Charger Data cable to the LOCAL charger’s CommsGenius, operation of chargers becomes synchronized in all respects. The LOCAL charger hosting the CommsGenius is in control while the REMOTE charger mirrors the LOCAL charger’s operation. The REMOTE charger’s settings are automatically set to agree with those of the LOCAL charger. The front control panel of the REMOTE charger becomes inactive. If the REMOTE charger is equipped with a Form C alarm card, its alarms will continue to report status of only the REMOTE charger. The alarm thresholds will have changed to become identical to those of the LOCAL charger.

### 5.2. Load Share Operation

Once the chargers are connected via the REMOTE Charger Data cable, load sharing will occur automatically. Load sharing can be turned off only by disconnecting the REMOTE Charger Data cable.

### 5.3. Load Share Troubleshooting

- Load share responds slowly: *1 to 2 minutes initial load sharing pickup response time is normal.* Load sharing requires the output voltages of the chargers to be very closely matched. Load share adjustments occur in very small steps, to ensure the narrow range where satisfactory sharing occurs will be found reliably. Once load share is established chargers will track each other quickly regardless of step load changes.
- Uneven load sharing: *Up to 10% difference between the chargers is normal.* For best results, the DC output wiring from each charger to the point of common coupling (load, battery, or power distribution center) should be designed for equal voltage drops in each charger output cable: equal wire lengths, equal wire gauges, and a symmetrical configuration rather than a bus structure.

- Unless the chargers have equal temperature sensor readings, temperature compensation should be disabled. Best practice is to use the SENS remote temperature sensor accessory connected to CommsGenius. Local temperature sensors will work only if both chargers have similar air temperatures at their bottom ventilation grilles: side by side installation is acceptable, but mounting one charger above the other allows hot air exiting the lower charger to pre-heat the air entering the upper unit. That causes significant temperature sensing error, which reduces that charger's set point and consumes load share adjustment range to correct for the temperature differential.
- "Positive ground fault" alarm indication: This can occur when a load sharing charger is equipped with output blocking diodes (last numeric character in charger model number is "3" or "4"), and the charger is disabled (AC failure, etc.) while the DC output circuit breaker is closed. The blocking diode disconnects the negative output terminal from the charger's ground fault sensing bridge, while the positive output remains connected. This asymmetry causes a weak ground fault current to flow in the positive output, which the *other* charger detects, causing a ground fault indication. To avoid this alarm, the ground fault sensitivity setting must be LOW or OFF. The ground current is real, and can be detected by the more sensitive ground fault thresholds.

## 6 Remote Temperature Sensor Operation

---

The Remote Temperature Sensor is located at the batteries and provides battery temperature data to a charger so it can appropriately adjust its output voltage depending on temperature (temperature compensation). The Remote Temperature Sensor also provides a common source of battery temperature data for temperature compensation of both chargers in a redundant charger system.

Connecting the Remote Temperature Sensor automatically enables remote temperature compensation. See Section 2 for installation instructions. Local (at the IQ charger) temperature compensation is default when a CommsGenius is not included. Use the IQ charger front panel controls to disable both local and remote temperature compensation. Remote temperature compensation may also be enabled/disabled using the *SENS IQ & CommsGenius Setup Utility* software.

### 6.1 Sensor Placement

The best sensor location is one that best detects temperature of the battery's electrolyte. Other sensor locations can give false readings and cause incorrect battery charging.

Fix the sensor to the battery terminal or case. ***Do not damage the battery case or otherwise compromise the integrity of the battery case.***

- Ideal connection is to a terminal of the battery jar in the warmest location. This will often be the mechanical center of a battery string. Connect the sensor to the battery terminal using readily available hardware, preferably stainless steel to prevent corrosion.
- Alternatively, fix the sensor to the battery case with a high strength adhesive or other method that will not unduly stress the battery case.
- Locate the sensor near the center of a vertical side of the battery case.
- Do not place battery atop the sensor.
- Place the sensor where it will not collide with nearby battery jar(s) or rack even with worst-case swelling of battery case or movement of battery and rack, as might be expected during earthquake or other mechanical shock.

## 6.2 Electrical and Wiring Considerations

One or two IQ chargers connected to a CommsGenius can use an electrically isolated remote sensor attached to TB15 of the CommsGenius. The sensor is suitable for air temperature sensing, surface sensing, and for attachment to a battery terminal. The sensor is not polarized. ***For battery terminal sensing, SENS recommends attaching the CommsGenius remote temperature sensor to the terminal attached to the grounded conductor of the battery system.*** The sensor circuit operates at the same low voltage as the data communications circuits (5Vdc) regardless of the chargers' DC output rating. The sensor circuit is current and power limited, meeting Code requirements for a Class 2 circuit.

See the EnerGenius IQ charger manual for further temperature compensation information.

## 7 Modbus Network Communications Operation

Modbus data communications will be available when the optional remote communications processor daughter board is included in an IQ charger.

Modbus is an application layer messaging protocol used for client/server communication and was implemented according to *Modbus Application Protocol Specification V1.1b* and *Modbus over serial line specification and implementation guide V1.02* provided by Modbus-IDA (<http://www.Modbus-IDA.org>).

*Modbus is a registered trademark of Schneider Automation Inc.*

*SENS and EnerGenius are registered trademarks of Stored Energy Systems LLC.*

The user may select to use Modbus over either RS-485 (detachable terminal block) or 10Base-T TCP/IP Ethernet (RJ-45 connector). Two modes of operation exist for Modbus over RS-485: Modbus ASCII or Modbus RTU.

Most functions are available over the network. However, network access must first be enabled through the USB Maintenance Port using the *SENS IQ & CommsGenius Setup Utility* software. The Network Access flag is available under the Internal Control pull-down menu. The following functions are never available over the network:

- Change number of cells in battery
- Change Cell Chemistry

### 7.1 Boolean Status (Binary Inputs), Modbus Function 0x02

Address	Name	Description	Access	
			USB	Network
<b>Internal STATUS (Addressed as BITS, read 8 bits per BYTE, lowest address is LSB of first byte)</b>				
0x0000	Nonvolatile Memory Read Error	On indicates error encountered when reading on-board nonvolatile memory	R	R
0x0001	On-Board Battery Low	On indicates on-board battery voltage is low.		
0x0002	Remote Temp Sensor Error	When true remote temperature sensor reading is in error.		
0x0003	Remote Temp Sensor Short	When true indicates Temp sensor error is a short		
0x0004	Remote Temp Sensor Open	When true indicates Temp sensor error is an open		

Address	Name	Description	Access	
			USB	Network
0x0005	Charger1 Comm Fail	True = CommsGenius has lost communications with Charger1. False = Communications with Charger1 are normal.	R	R
0x0006	Charger2 Comm Fail	True = CommsGenius has lost communications with Charger2. False = Communications with Charger2 are normal.	R	R
<b>CHARGER 1 STATUS (Addressed as BITS, read 8 bits per BYTE, lowest address is LSB of first byte)</b>				
0x0100	Summary Alarm	Alarm status: On = Alarm, Off = OK	R	R
0x0101	Charger Fail Alarm		R	R
0x0102	AC Fail Alarm		R	R
0x0103	High DC Voltage Alarm		R	R
0x0104	Ground Fault Alarm		R	R
0x0105	Battery Fault Alarm		R	R
0x0106	Low DC Voltage Alarm		R	R
0x0107	End Discharge Limit Alarm		R	R
0x0108	Equalize Charge	Equalize charge active (for any reason)	R	R
0x0109	Current Limit	Output at maximum current	R	R
0x010A	Thermal Limit	Thermal protection active	R	R
0x010B	DC Breaker Open	DC breaker open	R	R
0x010C	Reverse Polarity	Reverse polarity at output	R	R
0x010D	Positive Ground	Positive ground fault	R	R
0x010E	Negative Ground	Negative ground fault	R	R
0x010F	Battery Discharge	Voltage below discharge threshold	R	R
0x0110	Redundancy Check	Charger will not support system load	R	R
0x0111	OverVoltage Shutdown	True = an over voltage condition has caused charger to shut down	R	R
0x0112	Low Output Current	True = Output current is below low current alarm setting	R	R
0x0113	Battery Overtemp	True = Temperature sensor indicates battery is over temp	R	R
0x0114	Temp Sensor Fail	True = Temperature sensor reading out of range.	R	R
<b>CHARGER 2 STATUS (Addressed as BITS, read 8 bites per BYTE, lowest address is LSB of first byte)</b>				
0x0200	Summary Alarm	Alarm status: On = Alarm, Off = OK	R	R
0x0201	Charger Fail Alarm		R	R
0x0202	AC Fail Alarm		R	R
0x0203	High DC Voltage Alarm		R	R
0x0204	Ground Fault Alarm		R	R

Address	Name	Description	Access	
			USB	Network
0x0205	Battery Fault Alarm		R	R
0x0206	Low DC Voltage Alarm		R	R
0x0207	End Discharge Limit Alarm		R	R
0x0208	Equalize Charge	Equalize charge active (for any reason)	R	R
0x0209	Current Limit	Output at maximum current	R	R
0x020A	Thermal Limit	Thermal protection active	R	R
0x020B	DC Breaker Open	DC breaker open	R	R
0x020C	Reverse Polarity	Reverse polarity at output	R	R
0x020D	Positive Ground	Positive ground fault	R	R
0x020E	Negative Ground	Negative ground fault	R	R
0x020F	Battery Discharge	Voltage below discharge threshold	R	R
0x0210	Redundancy Check	Charger will not support system load	R	R
0x0211	OverVoltage Shutdown	True = an over voltage condition has caused charger to shut down	R	R
0x0212	Low Output Current	True = Output current is below low current alarm setting	R	R
0x0213	Battery Overtemp	True = Temperature sensor indicates battery is over temp	R	R
0x0214	Temp Sensor Fail	True = Temperature sensor reading out of range.	R	R

7.2 Boolean Read/Write Controls (Binary Outputs), Modbus Functions 0x01, 0x05, 0x0F

Address	Name	Description	Default	Access	
				USB	Network
<b>SYSTEM CONTROLS (Addressed as BITS, read/write 8 bites per BYTE, lowest address is LSB of first byte. All chargers use the same settings)</b>					
0x1000	Periodic Equalize	Repeat timed equalize cycles at scheduled intervals	Off	R/W	R/W
0x1001	Periodic Battery Check	Invoke battery check at scheduled intervals	Off	R/W	R/W
0x1002	Periodic Redundancy Test	Repeat both redundancy tests at scheduled intervals	Off	R/W	R/W
0x1003	Temperature Compensation	Enable battery voltage temperature compensation	Off	R/W	R/W
0x1004	Timed Equalize	Perform single timed equalize cycle	Off	R/W	R/W
0x1005	Automatic Equalize	Automatic, time-limited equalize charge	Off	R/W	R/W
0x1006	Float Mode	Disables timed and automatic equalize charging	Off	R/W	R/W
0x1007	Battery Check	Perform a single timed battery check. Battery check begins on rising edge. Signal remains high for duration of battery check, automatically switches low	Off	R/W	R/W

Address	Name	Description	Default	Access	
				USB	Network
		at end of timed check. Falling edge forces early termination.			
0x1008	Redundancy Check	Perform a single redundancy check	Off	R/W	R/W
0x1009	Demand Based Equalize	Perform a single equalize cycle	Off	R/W	R/W

**Internal Read-Write Control**

Address	Name	Description	Scale	Access	
				USB	Network
0x1300	Network Access	Allow/disallow network write access. Write access is through USB only	1	R/W	R
0x1301	Second Charger Installed	True indicates to CommsGenius that a second charger is installed on the remote port	1	R/W	R/W
0x1302	Reset Network Connection	True causes CommsGenius to reset the network board. Automatically reset to false after network board is reset.	N/A	W	N/A
0x1303	Save Settings	Writing a non-zero value saves all settings to non-volatile memory	N/A	W	W

7.3 Numeric Read-Only Values, Modbus Function 0x04

Address	Name	Description	Scale	Access	
				USB	Network
<b>SYSTEM VALUES</b>					
0x2000	Equalize Timer	Minutes remaining for this equalize cycle	100	R	R
0x2001	Battery Check Timer	Seconds remaining for this battery check	1	R	R
0x2002	Redundancy Check Timer	Seconds remaining for this redundancy check	1	R	R
0x2003	Remote Temperature Sensor	Temp. comp. sensor reading, 235 = 23.5°C	1	R	R
<b>CHARGER 1 VALUES</b>					
0x2100	Rated Output Voltage	12, 24, 48, 120, or 240 Vdc	1	R	R
0x2101	Rated Output Current	6, 12, 16, 25, 35, 50, 75, 100, or 150 Adc	1	R	R
0x2102	Output Voltage	1351 = 13.51Vdc	100	R	R
0x2103	Output Current	4950 = 49.50Adc	100	R	R
0x2104	Percent Input Voltage	101 = 101% of rated input voltage	100%	R	R
0x2105	Internal Temperature Sensor	Temp. comp. sensor reading, 235 = 23.5°C	10	R	R
0x2106	Heat Sink Temperature	850 = 85.0°C	10	R	R
0x2107	Elapsed Time Months	Elapsed time since charger power on: 28 day "months" (0-1775),	1	R	R

Address	Name	Description	Scale	Access	
				USB	Network
0x2108	Elapsed Time Hours	hours (0-671), minutes (0-59), seconds (0-59)	1	R	R
0x2109	Elapsed Time Minutes		1	R	R
0x210A	Elapsed Time Seconds		1	R	R
<b>CHARGER 2 VALUES</b>					
0x2200	Rated Output Voltage	12, 24, 48, 120, or 240 Vdc	1	R	R
0x2201	Rated Output Current	6, 12, 16, 25, 35, 50, 75, 100, or 150 Adc	1	R	R
0x2202	Output Voltage	1351 = 13.51Vdc	100	R	R
0x2203	Output Current	4950 = 49.50Adc	100	R	R
0x2204	Percent Input Voltage	101 = 101% of rated input voltage	100%	R	R
0x2205	Internal Temperature Sensor	Temp. comp. sensor reading, 235 = 23.5°C	10	R	R
0x2206	Heat Sink Temperature	850 = 85.0°C	10	R	R
0x2207	Elapsed Time Months	Elapsed time since charger power on: 28 day "months" (0-1775), hours (0-671), minutes (0-59), seconds (0-59)	1	R	R
0x2208	Elapsed Time Hours		1	R	R
0x2209	Elapsed Time Minutes		1	R	R
0x220A	Elapsed Time Seconds		1	R	R

7.4 Read-Write Settings, Modbus Functions 0x03, 0x06, & 0x10

Address	Name	Description	Scale	Access	
				USB	Network
<b>SYSTEM SETTINGS (all chargers use the same settings)</b>					
0x3000	Float Setpoint per Cell	Vdc per cell, 2220 = 2.220V/cell	1000	R/W	R/W0
0x3001	Equalize Setpoint per Cell	Vdc per cell, 2350 = 2.350V/cell	1000	R/W	R/W0
0x3002	Equalize AC On Delay	Minutes equalize inhibited after AC on	1	R/W	R/W0
0x3003	Equalize Time Limit	Manual/automatic equalize time-out, hours	1	R/W	R/W0
0x3004	Equalize Time Interval	Days between scheduled equalize cycles	1	R/W	R/W0
0x3005	Volt per Cell Temp. Coefficient	-mVdc/cell/°C, 400 = -400mV/cell/°C	-100	R/W	R/W0
0x3006	Current Limit Percentage	% Rated Adc, 105 = 105%	100%	R/W	R/W0
0x3007	Low Current Alarm	% Rated Adc, 25 = 25%	100%	R/W	R/W
0x3008	High DC Alarm per Cell	Vdc per cell, 2450 = 2.450V/cell	1000	R/W	R/W

Address	Name	Description	Scale	Access	
				USB	Network
0x3009	Over Voltage Shutdown	Vdc per cell, 2450 = 2.450V/cell	1000	R/W	R/W
0x300A	Batt. Disch. Alarm. per Cell	Vdc per cell, 2050 = 2.050V/cell	1000	R/W	R/W
0x300B	Low DC Alarm. per Cell	Vdc per cell, 1850 = 1.850V/cell	1000	R/W	R/W
0x300C	End Disch. Alarm per Cell	Vdc per cell, 1750 = 1.750V/cell	1000	R/W	R/W
0x300D	Ground Alarm Sensitivity	Enum: 0-3 = disable/low/med/high leakage	N/A	R/W	R/W
0x300E	Alarm Relay Delay	Seconds delayed (except AC fail)	1	R/W	R/W
0x300F	Battery Test Alarm per Cell	Vdc per cell, 2000 = 2.000V/cell	1000	R/W	R/W
0x3010	Battery Check Duration	Length of battery check, minutes	1	R/W	R/W
0x3011	Battery Check Interval	Days between scheduled checks	1	R/W	R/W
0x3012	DC Bus Minimum	Vdc per cell, 2000 = 2.000V/cell	1000	R/W	R/W
0x3013	Redundancy Check per Cell	Vdc per cell, 2175 = 2.175V/cell	1000	R/W	R/W
0x3014	Redundancy Check Duration	Length of Redundancy check, seconds	1	R/W	R/W
0x3015	Redundancy Check Interval	Minutes between scheduled checks	1	R/W	R/W
0x3016	Cell Count	Number of cells in battery string	1	R/W	R
0x3017	Cell Chemistry	0 = NiCd, 1 = VRLA, 2 = Flooded	N/A	R/W	R
<b>SYSTEM REAL-TIME CLOCK</b>					
0x3080	Real-Time Clock Second	Real-Time Clock Data: Second: 0-59, Minute: 0-59, Hour: 0-23, Day of Week: 1-7 = Sun-Sat, Date: 1-31 Month: 1-12 = Jan-Dec, Year: 0-99 (starting at 0 = 2000)	1	R/W	R/W
0x3081	Real-Time Clock Minute		1	R/W	R/W
0x3082	Real-Time Clock Hour		1	R/W	R/W
0x3083	Real-Time Clock Day of Week		1	R/W	R/W
0x3084	Real-Time Clock Date		1	R/W	R/W
0x3085	Real-Time Clock Month		1	R/W	R/W
0x3086	Real-Time Clock Year		1	R/W	R/W

**7.5 Communication Settings**

Communication settings can be changed only through the USB port. To prevent loss of network communications, these settings are read-only via the RS-485 and TCP/IP networks regardless of the network write-enable setting (see address 0x1300).

Address	Name	Description	Scale
0xF000	Network Protocol	Enumerated: 1 = serial Modbus ASCII 2 = serial Modbus RTU 3 = Modbus TCP/IP 4 = serial DNP3 5 = DNP3 TCP/IP	1
0xF001	RS-485 Parity	Enumerated: 0 = none, 1 = odd, 2 = even (default)	1
0xF002	RS-485 Data Rate	Baud / 10 (typ. characters / second): 11 = 110 Baud 30 = 300 Baud 60 = 600 Baud 120 = 1200 Baud 240 = 2400 Baud 480 = 4800 Baud 960 = 9600 Baud 1440 = 14400 Baud 1920 = 19200 Baud (default) 2880 = 28800 Baud 3840 = 38400 Baud 5760 = 57600 Baud 11520 = 115200 Baud	0.1
0xF003	RS-485 On/Off Delay	Bus transceiver enable/disable delay (msec)	1
0xF004	Number of data bits	7 or 8	1
0xF005	Number of stop bits	1 or 2	1
0xF010	tcpIpAddr3	TCP/IP address: 64 bits, high order to low order <sup>[1]</sup>	1
0xF011	tcpIpAddr2		1
0xF012	tcpIpAddr1		1
0xF013	tcpIpAddr0		1
0xF014	subNetMask3	TCP/IP subnet mask: 64 bits, high order to low order <sup>[1]</sup>	1
0xF015	subNetMask2		1
0xF016	subNetMask1		1
0xF017	subNetMask0		1
0xF018	networkGateway3	Gateway address: 64 bits, high order to low order <sup>[1]</sup>	1
0xF019	networkGateway2		1

<sup>1</sup> TCP/IP addresses are allocated four words (64 bits) to permit future migration to TCP/IP version 6. For 32 bit addresses (TCP/IP version 4) the two low-order words are used, and the high-order words are ignored. The data is stored "Big-Endian", with the most significant byte first.

Address	Name	Description	Scale
0xF01A	networkGateway1		1
0xF01B	networkGateway0		1
0xF01C	networkTimeOut		Network time-out parameter (msec)
0xF030	Modbus Address	Modbus serial interface address (1-247)	1
0xF031	TCP/IP Port	Port number for TCP/IP. Default = 502.	1

7.6 Device Information Strings, Modbus Function 0x2B

Address	Name	Description (All are ASCII text strings)	Read Dev ID Codes
0x01	Product Code	Serial number text (eg, "123456")	1, 2, 3, 4
0x02	MajorMinorRevision	Communication board software revision (eg, "2.01")	1, 2, 3, 4
0x05	Model Name	CommsGenius model number	2, 3, 4
0x80	CommsGenius Build Date	eg, "Jul 1 2007"	3, 4
0x90	Charger 1 Serial Number	Serial number text (eg, "123456")	3, 4
0x91	Charger 1 Software Rev.	As shown on UI display (eg, "M1.02/C1.05")	3, 4
0x92	Charger 1 Model Number	eg, "Q024075TL514B"	3, 4
0x93	Charger 1 Build Date	eg, "Jul 1 2007"	3, 4
0xA0	Charger 2 Serial Number	Serial number text (eg, "123456")	3, 4
0xA1	Charger 2 Software Rev.	As shown on UI display (eg, "M1.02/C1.05")	3, 4
0xA2	Charger 2 Model Number	eg, "Q024075TL514B"	3, 4
0xA3	Charger 2 Build Date	eg, "Jul 1 2007"	3, 4

7.7 IQ and CommsGenius Settings Limits

Parameter	Integer Data Values				Charger Front Panel Display Values		
	Scaling and Units	Battery Cell Type			Battery Cell Type		
		Nickel-Cadmium	VRLA	Flooded lead acid	Nickel-Cadmium	VRLA	Flooded lead acid
Battery Check Minimum DC Bus Voltage	100 * % Nominal Voltage	10300	10300	10300	1.287	2.060	2.060
		9000	9000	9000	1.125	1.800	1.800
End Discharge Alarm	10000 * V/Cell	14000	22000	22000	1.400	2.200	2.200
		10000	17000	17000	1.000	1.700	1.700
Low DC Voltage Alarm	10000 * V/Cell	14000	22000	22000	1.400	2.200	2.200
		10000	17000	17000	1.000	1.700	1.700
Battery on Discharge Alarm	10000 * V/Cell	14000	22000	22000	1.400	2.200	2.200
		10000	17000	17000	1.000	1.700	1.700

Float Charge Voltage	10000 * V/Cell	16000 12000	24500 20000	24500 20000	1.600 1.200	2.450 2.000	2.450 2.000
Equalize Charge Voltage	10000 * V/Cell	16000 12000	24500 20000	24500 20000	1.600 1.200	2.450 2.000	2.450 2.000
High DC Voltage Alarm	10000 * V/Cell	17000 15000	25000 22000	25000 22000	1.700 1.500	2.500 2.200	2.500 2.200
Overvoltage Shutdown	10000 * V/Cell	17500 15000	26000 22000	26000 22000	1.750 1.500	2.600 2.200	2.600 2.200
Time Between Equalize Charge (Interval)	1 * Days	180 1	180 1	180 1	180 1	180 1	180 1
Temperature Compensation Slope	-100 * mV/Cell/°C	400 75	550 100	550 100	4.00 0.75	5.50 1.00	5.50 1.00
Demand-Based Equalize Time Delay (at power-on)	1 * Minutes	5 0	5 0	5 0	5 0	5 0	5 0
Equalize Time Limit	1 * Hours	255 1	255 1	255 1	255 1	255 1	255 1
Current Limit	100 * % Rated Current	11000 3300	11000 3300	11000 3300	110% 33%	110% 33%	110% 33%
Low Current Alarm	100 * % Rated Current	5100 5000 200	5100 5000 200	5100 5000 200	Disabled 50% 2%	Disabled 50% 2%	Disabled 50% 2%
Alarm Relay Delay	1 * Seconds	50 5	50 5	50 5	50 5	50 5	50 5
Battery Check Interval	1 * Days	60 1	60 1	60 1	60 1	60 1	60 1
Battery Check Duration	1 * Minutes	60 1	60 1	60 1	60 1	60 1	60 1
Ground Fault Alarm Sensitivity	Enumerated	1 2 3 4	1 2 3 4	1 2 3 4	High Med Low Off	High Med Low Off	High Med Low Off
Battery Cell Type	Enumerated	0	1	2	Nickel-Cadmium	VRLA	Flooded lead acid
Battery Cell Count	12V Models	10	6	6	10	6	6
		6	4	4	6	4	4
	24V Models	20	12	12	20	12	12
		12	8	8	12	8	8
	48V Models	40	24	24	40	24	24
25		16	16	25	16	16	
120V Models	96	60	60	96	60	60	
	64	40	40	64	40	40	
240V Models	192	120	120	192	120	120	
	128	80	80	128	80	80	

## APPENDIX A: Modbus Address Reference by Function Type

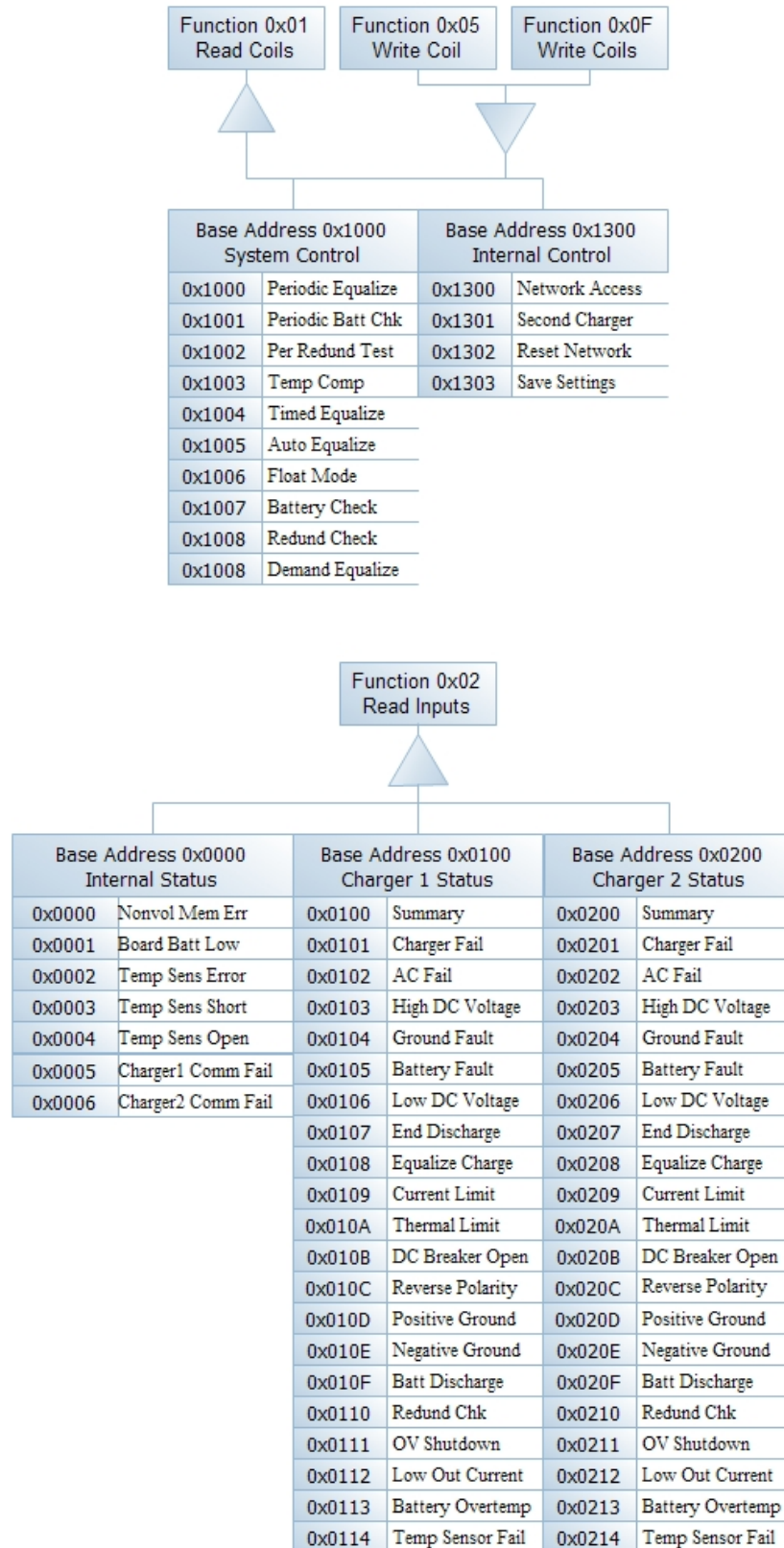

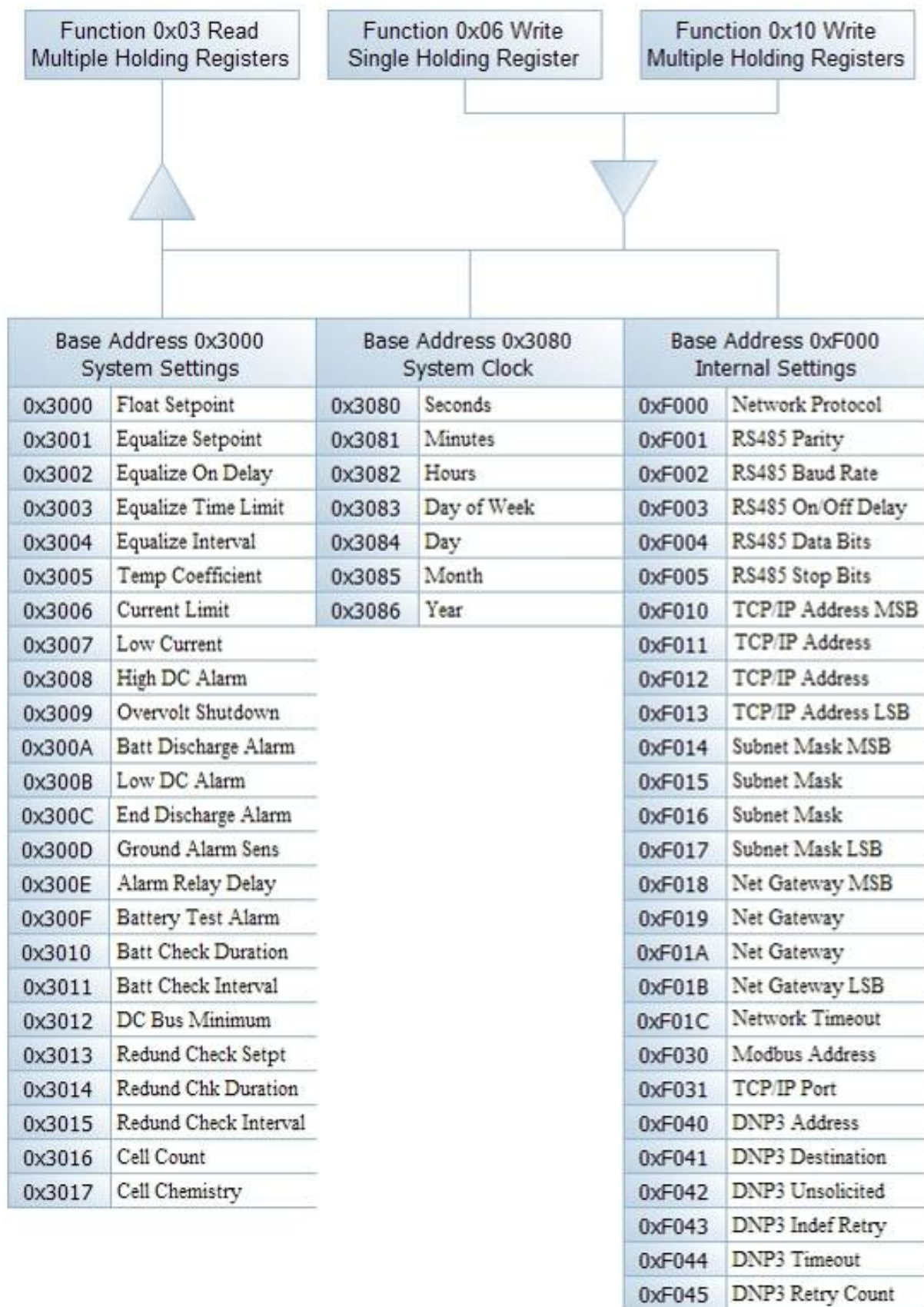

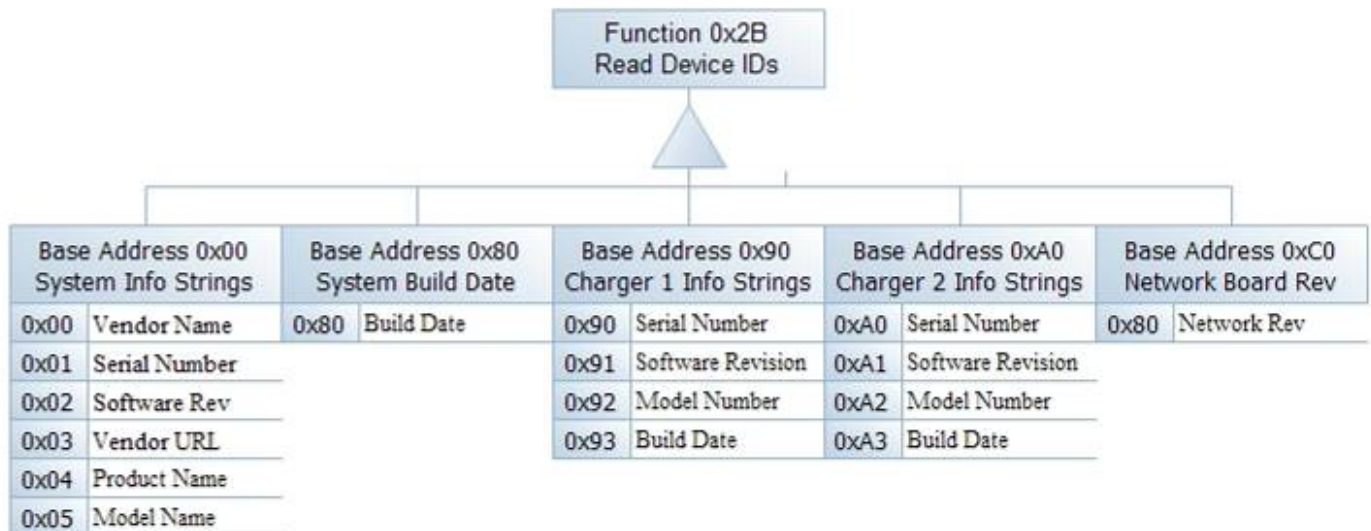
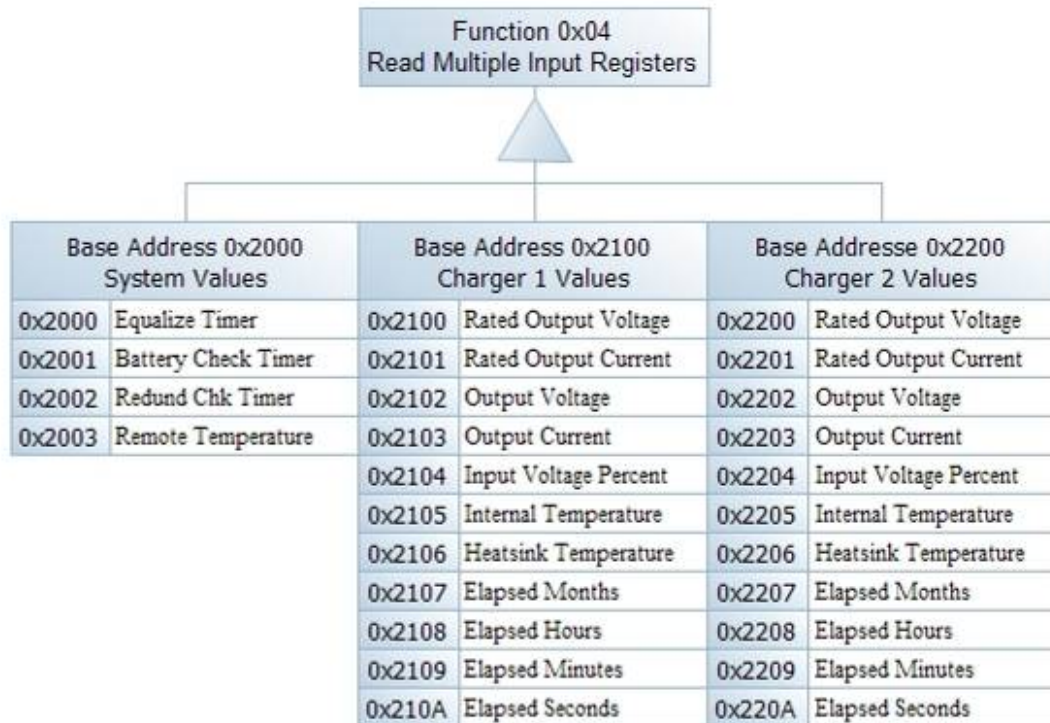

## APPENDIX B: IQ Charger Voltage Setting Interlocks

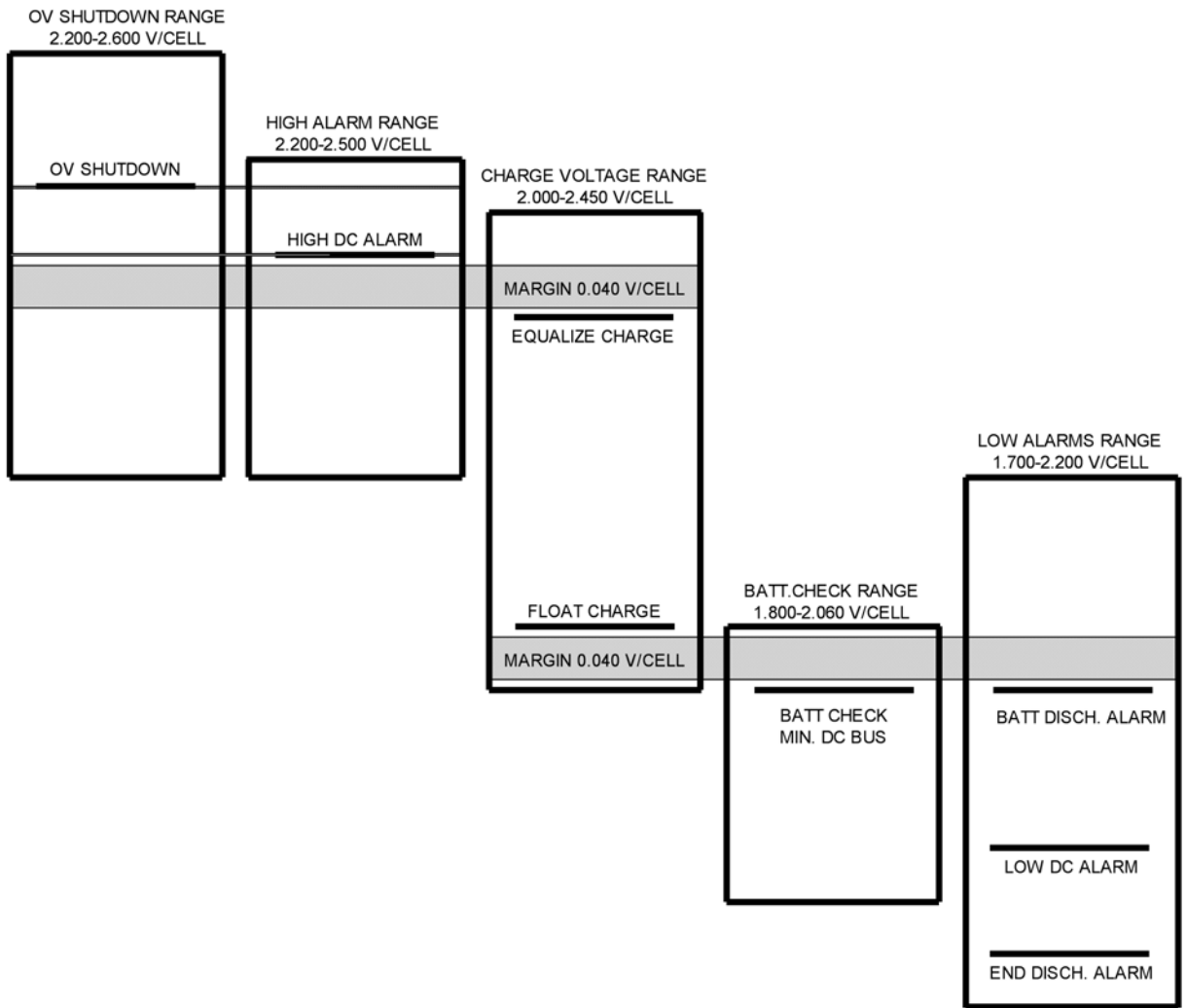

**IQ CHARGER ADJUSTMENT LIMITS FOR FLOODED AND VRLA BATTERIES**

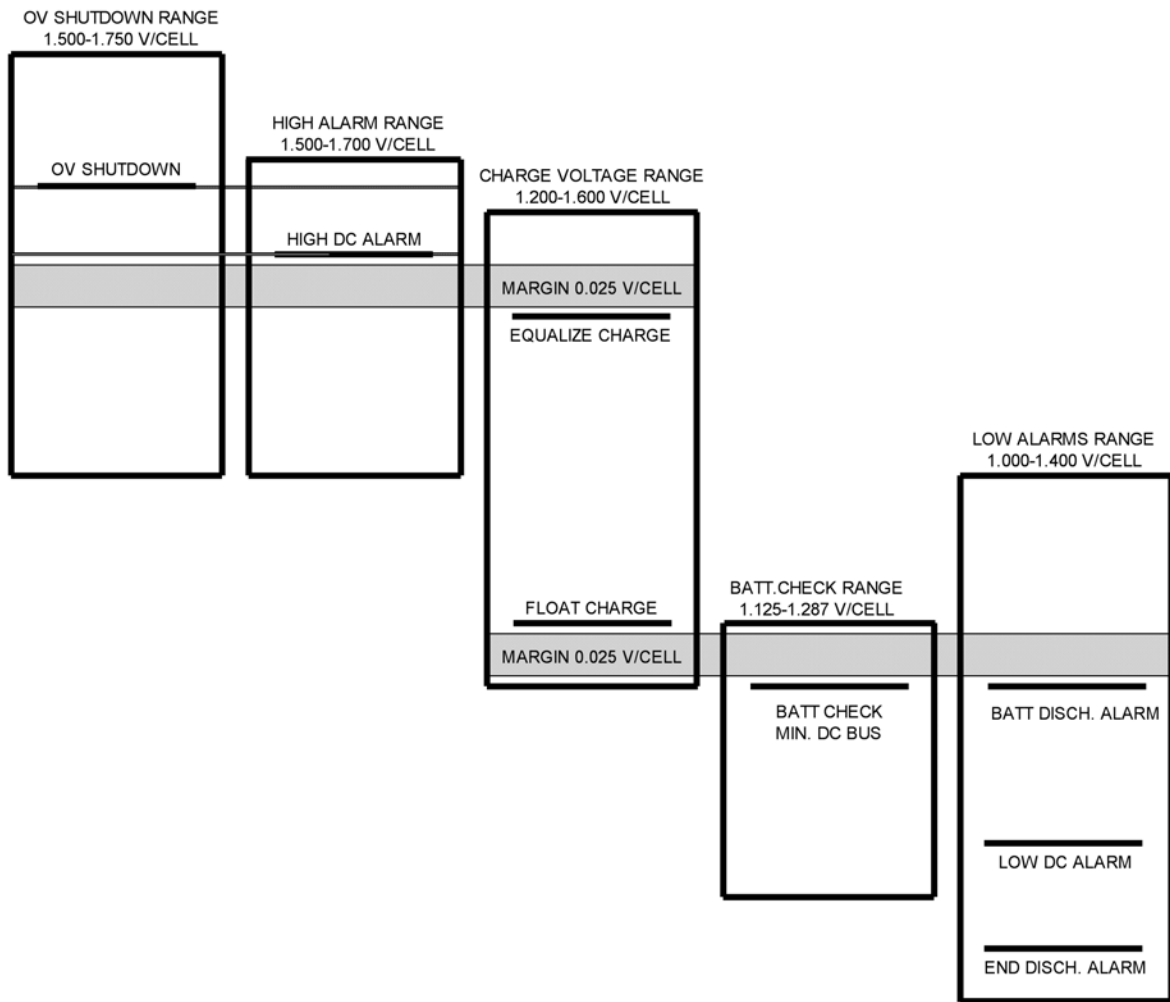

### IQ CHARGER ADJUSTMENT LIMITS FOR NICKEL-CADMIUM BATTERIES

Notes for IQ Charger Adjustment Limits:

- All settings have absolute minimums and maximums, shown by the heights of the five rectangular boxes. Those settings in each rectangular box share the same absolute limits. The absolute limits vary according to cell chemistry, as shown in the separate graphs for lead-acid and nickel-cadmium battery chemistries.
- There also are relative limits between settings. Settings must be in this order:

$$\begin{aligned}
 &\text{OV Shutdown} \geq \text{HV Alarm} \\
 &\text{HV Alarm} \geq (\text{Equalize Charge} + 2\% \text{ Vnominal}^{[2]}) \\
 &\text{Equalize Charge} \geq \text{Float Charge} \\
 &\text{Float Charge} \geq (\text{Battery Check Minimum DC Bus} + 2\% \text{ Vnominal}^{[2]}) \\
 &\text{Float Charge} \geq (\text{Battery Discharging Alarm} + 2\% \text{ Vnominal}^{[2]}) \\
 &\text{Battery Discharging Alarm} \geq \text{Low DC Alarm} \\
 &\text{Low DC Alarm} \geq \text{End of Discharge Alarm}
 \end{aligned}$$

<sup>2</sup> Flooded lead-acid and valve-regulated lead-acid cells are 2.000V/cell nominal, so the 2% margins are 0.040V/cell for these types. Nickel-cadmium cells are 1.250V/cell nominal, so the 2% margins are 0.025V/cell for Nicad batteries.

- Periodic Equalize schedule: You may have up to two hours of Periodic Equalize per day of Equalize Interval:

$$[\text{Equalize Time Limit (hrs)}] \leq [2 * \text{Days Between Periodic Equalize (days)}]$$

- For enhanced product safety, the OV Shutdown setting can be changed only when the hardware "panel unlock" jumper is in the unlocked position. For normal operation, the jumper should be locked to prevent inadvertent changes to this important setting.
- The charger's front panel changes one setting at a time. Adjustments beyond the absolute limits or relative limits are not accepted. Attempting to exceed the limits produces an audible warning beep.
- The *SENS IQ & CommsGenius Setup Utility* checks all settings changes against absolute and relative limits before transferring them to CommsGenius. This ensures that charger settings will be acceptable before applying the changes.
- Settings changes made via network connections will be checked when received by CommsGenius. Settings that are inconsistent with the absolute or relative limits will be rejected and not transferred to the IQ chargers.
- If settings inconsistent with the absolute and relative limits described above are sent to the charger, the conflicts will be resolved as follows:
  1. If the new set of values does not satisfy the absolute and relative limits, CommsGenius will reject the adjustment command with a "data values" error. No changes will occur to any of the chargers' settings.
  2. If the hardware jumper is **unlocked** and the settings satisfy the absolute and relative limits described above, all setting changes will be applied to both chargers.
  3. If the hardware jumper is **locked**, the OV shutdown setting will not change. This may require other settings changes to resolve conflicts:
    - a. Apply the float charge setting. If it conflicts with the locked OV shutdown setting, reduce the float setting to resolve the conflict.
    - b. Apply the equalize charge setting. If it conflicts with the locked OV shutdown setting, reduce the equalize setting to resolve the conflict. This may result in identical equalize and float settings, which is permissible.
    - c. Apply the HV alarm setting. If it conflicts with the locked OV shutdown setting, reduce the HV alarm to resolve the conflict. This may result in identical HV alarm and OV shutdown settings, which is permissible.
    - d. Apply the Battery Discharging, Low DC, and End of Discharge alarm settings in that order. In each case, if the setting conflicts with the adjusted float voltage setting or a previous alarm setting, adjust the alarm setting downward to resolve the conflict. This may result in some alarm settings being identical, which is permissible.
    - e. Apply the battery check minimum DC bus setting. If it conflicts with the float charge setting, adjust minimum DC bus downward to resolve the conflict.

# APPENDIX C: CommsGenius System Diagram

## CommsGenius in Single and Dual IQ Configurations

