



## Installation & Operation Manual

NRG12-10: 12-Volt, 10-Amp Battery Charger

NRG24-10: 24-Volt, 10-Amp Battery Charger

NRG22-10: 12/24-Volt, 10-Amp Battery Charger

---

SENS Part Number: 101295  
Document Revision: Q  
DCN Number: 106080  
Date: January 17, 2012

Installation or service questions?  
Call SENS at 1.800.742.2326 (303.678.7500)  
between 8 a.m. and 5 p.m. (Mountain Time)  
Monday through Friday, or visit our website.

Copyright © Stored Energy Systems LLC 2006

  
*Our energy means business™*

1840 Industrial Circle  
Longmont, CO 80501

Phone: 303.678.7500  
800.742.2326

Fax: 303.678.7504

Email: [service@sens-usa.com](mailto:service@sens-usa.com)

Web: [www.sens-usa.com](http://www.sens-usa.com)

## IMPORTANT SAFETY INSTRUCTIONS FOR INSTALLER AND OPERATOR

---

1. **SAVE THESE INSTRUCTIONS.**
2. **DO NOT EXPOSE CHARGER TO RAIN OR SNOW.**
3. Use of an attachment not recommended or sold by SENS may result in a risk of fire, electric shock, or injury to persons.
4. **ONLY TRAINED AND QUALIFIED PERSONNEL MAY INSTALL AND SERVICE THIS UNIT.**
5. Do not operate charger if it has received a sharp blow, been dropped, or otherwise damaged in any way; shut off power at the branch circuit protectors and have the unit serviced or replaced by qualified personnel.
6. To reduce risk of electric shock, disconnect the branch circuit feeding the charger before attempting any maintenance or cleaning. Turning off controls will not reduce this risk.

**WARNING:  
RISK OF EXPLOSIVE  
GASES.**

- A. **WORKING IN THE VICINITY OF A LEAD-ACID OR NICKEL-CADMIUM BATTERY IS DANGEROUS. STORAGE BATTERIES GENERATE EXPLOSIVE GASES DURING NORMAL BATTERY OPERATION. FOR THIS REASON, IT IS OF UTMOST IMPORTANCE THAT EACH TIME BEFORE USING YOUR CHARGER, YOU READ THIS MANUAL AND FOLLOW THE INSTRUCTIONS EXACTLY.**
  - B. To reduce the risk battery explosion, follow these instructions and those published by the battery manufacturer and the manufacturer of any equipment you intend to use in the vicinity of a battery. Review cautionary markings on these products and on the engine.
7. **PERSONAL PRECAUTIONS**
- A. Someone should be within range of your voice or close enough to come to your aid when you work near a storage battery.
  - B. Have plenty of fresh water and soap nearby in case battery electrolyte contacts skin, clothing, or eyes.
  - C. Wear complete eye protection and clothing protection. Avoid touching eyes while working near a storage battery.
  - D. If battery electrolyte contacts skin or clothing, wash immediately with soap and water. If electrolyte enters eye, immediately flood the eye with running cold water for at least 10 minutes and get medical attention immediately.
  - E. **NEVER** smoke or allow a spark or flame in vicinity of battery or engine.
  - F. Be extra cautious to reduce risk of dropping a metal tool onto battery. It might spark or short circuit battery or other electrical part that may cause explosion. Using insulated tools reduces this risk, but will not eliminate it.
  - G. Remove personal metal items such as rings, bracelets, necklaces, and watches when working with a storage battery. A storage battery can produce a short circuit current high enough to weld a ring or the like to metal, causing a severe burn.
  - H. **Use this charger for charging LEAD-ACID or LIQUID ELECTROLYTE NICKEL-CADMIUM batteries only.** Do not use this battery charger for charging dry cells, alkaline, lithium, nickel-metal-hydride, or sealed nickel-cadmium batteries that are commonly used with home appliances. These batteries may burst and cause injuries to persons and damage to property.
  - I. **NEVER** charge a frozen battery.

**MODEL NUMBER CONFIGURATION**

This manual contains important safety, installation and operating instructions for SENS battery charger model NRG12-10 (configured for 12V,10A only), NRG24-10 (configured for 24V, 10A only) and NRG22-10 (field configurable for 12V or 24V, 10A).

**Model Number Breakout**

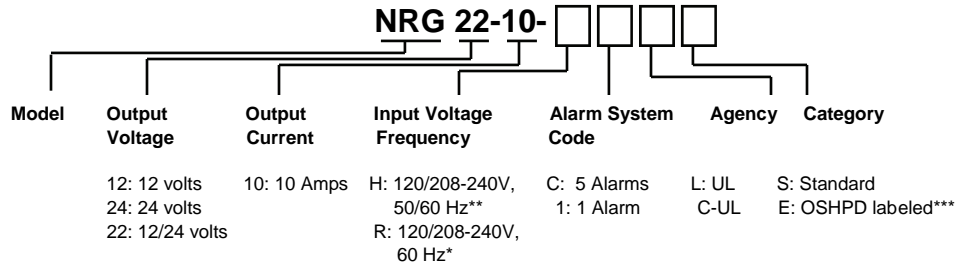

NOTE: Not all configurations are available on all models.  
Contact the factory for confirmation.  
\*UL listed, CSA certified  
\*\*UL listed, CSA certified and CE marked  
\*\*\*California Special Seismic Certification Pre-Approval

**INSTALLATION INSTRUCTIONS**

**WARNING:**  
**ONLY TRAINED AND QUALIFIED**  
**PERSONNEL MAY INSTALL AND SERVICE THIS UNIT.**

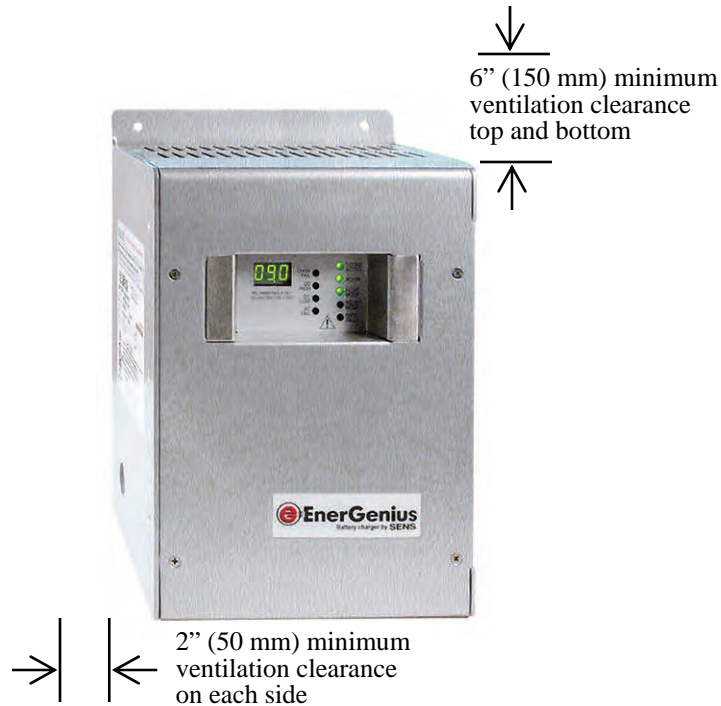

Mount to vertical surface of 3/4" (19 mm) plywood or other material of equal strength and durability, using four mounting screws 1/4" (6 mm) diameter.

**1. PREPARING FOR USE:**

**WARNING:**  
**ONLY TRAINED AND QUALIFIED**  
**PERSONNEL MAY INSTALL AND**  
**SERVICE THIS UNIT.**

- A. INSTALLATION OF THE UNIT MUST COMPLY WITH LOCAL ELECTRICAL CODES AND OTHER APPLICABLE INSTALLATION CODES.**
- B. INSTALLATION MUST BE MADE ACCORDING TO THE INSTALLATION INSTRUCTIONS AND ALL APPLICABLE SAFETY REGULATIONS.**

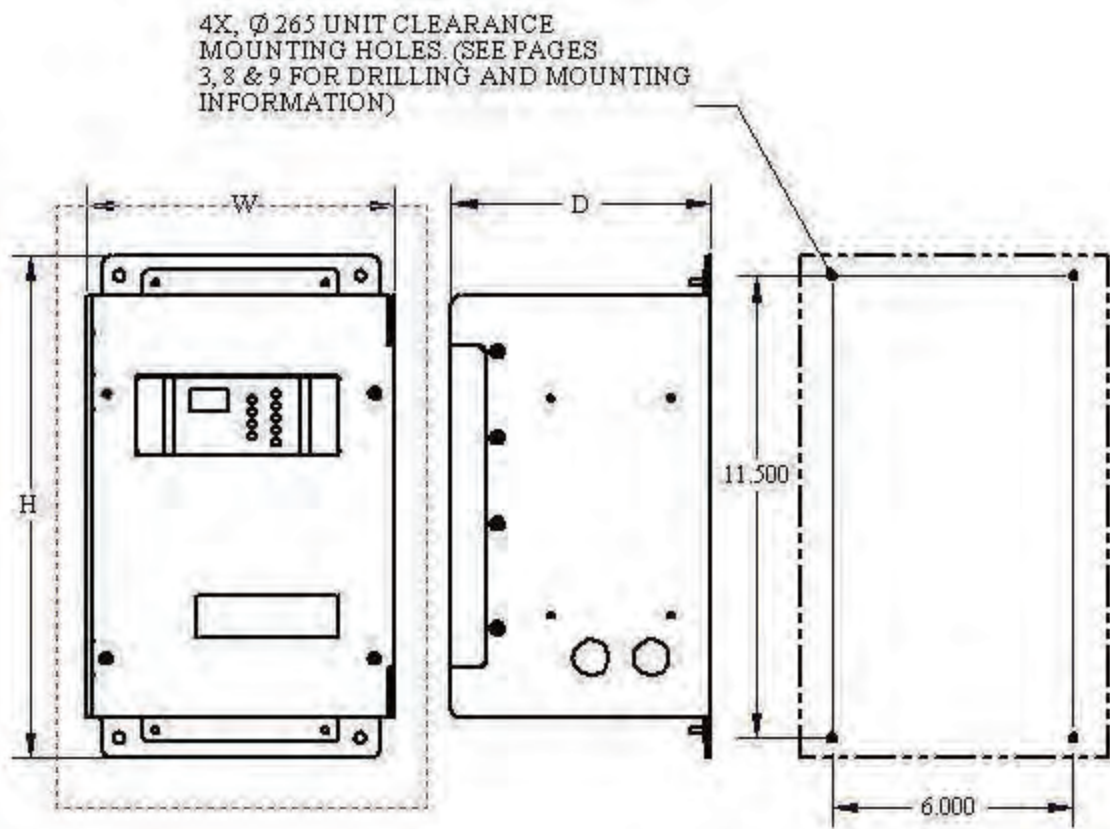

Charger Dimensions:

- W: 7.66 Inches (195 mm).
- H: 12.50 Inches (318 mm).
- D: 6.48 Inches (165 mm).

**FIVE ALARM MODEL  
SHOWN - SEE PAGE 3  
FOR MODEL NUMBER  
BREAKDOWN**

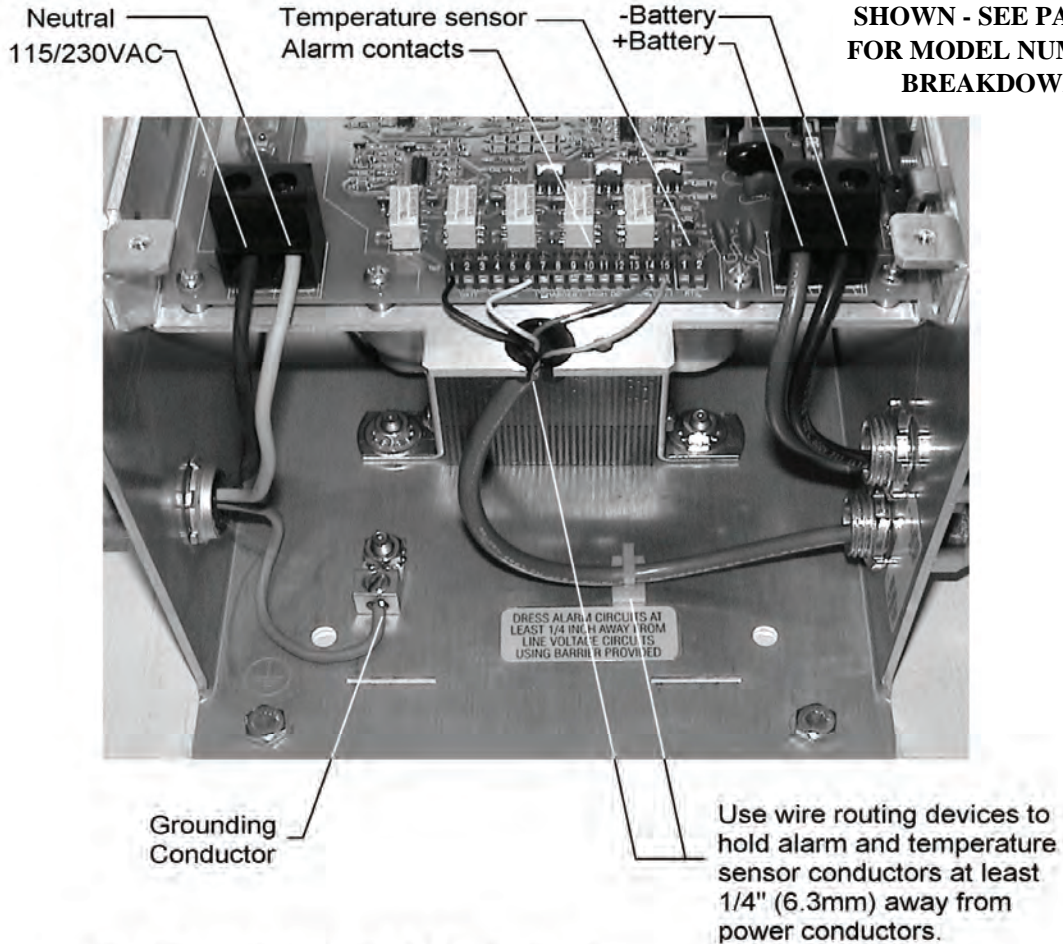

**Use conductors rated 90C or higher.  
Input conductors must be suitable for 10A circuits.  
Battery conductors must be suitable for 30A circuits. See Section 5.  
Alarm and temperature sensor may use low power conductors.**

- C. This unit is permanently connected to the AC circuit and to the battery. An external disconnect device with a minimum of 0.12”(3 mm) pole separation must be located in the AC input to the charger.
  - Do not energize the AC supply circuit until **ALL** wiring is connected, internal controls are properly set, and the cover is secured. Always shut the AC supply circuit off before installing or removing any wiring or opening the cover for any reason.
  - Always observe proper polarity of the DC output leads.
  - Always connect the output leads in this order: ungrounded charger output first, then ungrounded battery terminal, then grounded charger output, and grounded battery terminal last. If the battery must be disconnected for service, remove the output wiring in the reverse of the order given above.
- D. Be sure battery terminals are clean and properly tightened. Be careful to keep corrosion from coming in contact with eyes.
- E. Add distilled water to each cell until the electrolyte reaches the level specified by the battery manufacturer. This helps purge excess gas from the cells. Do not over fill. For a battery without cell caps, carefully follow the manufacturer’s recharging instructions.
- F. Study all battery manufacturer’s specific precautions such as removing or not removing cell caps while charging and recommended rates of charge.
  - The recommended charge current range must include the rated output current of this charger, which is 10 amperes.
  - Set the float voltage jumper to the battery manufacturer’s recommended float charge voltage. Incorrect charge voltage will accelerate generation of explosive gases, increasing the risk of fire or explosion.

Neutral 115/230VAC

Temperature Sensor Alarm Contacts

-Battery +Battery

ONE ALARM MODEL SHOWN- SEE PAGE 3 FOR MODEL NUMBER BREAKDOWN

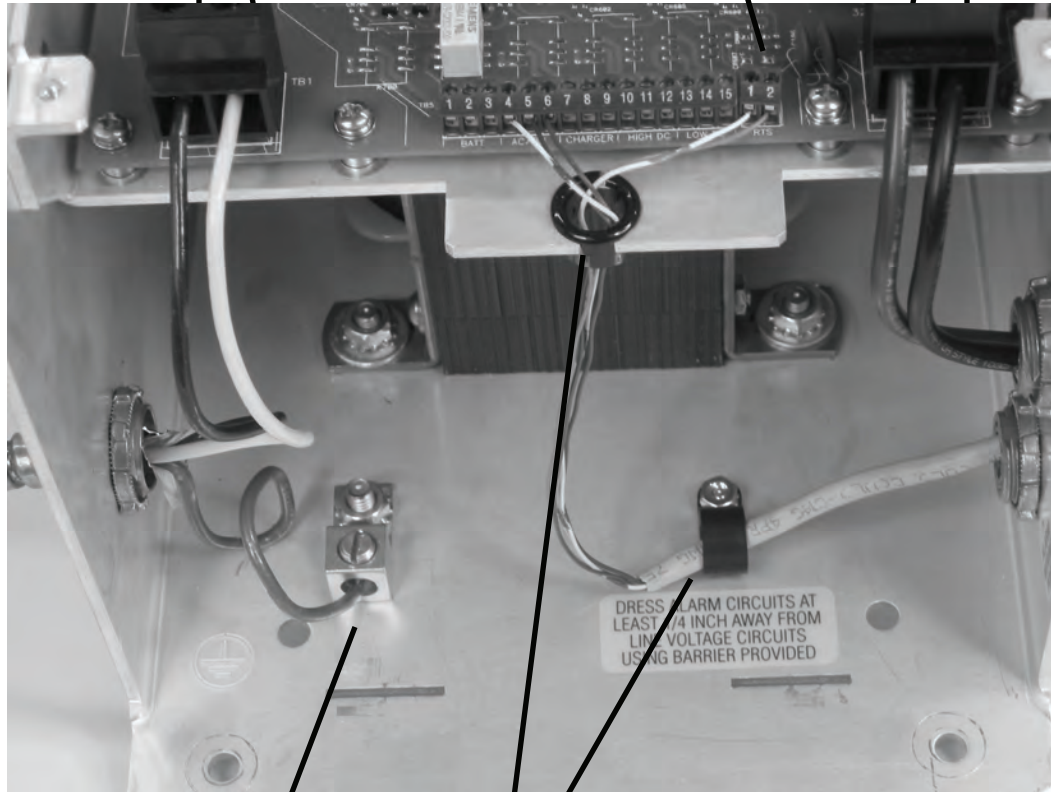

Grounding Conductor

Use wire routing devices to hold alarm and temperature sensor conductors at least 1/4" (6.3 mm) away from power conductors.

- G. Enable the automatic boost charge mode (equalizing charge) only if recommended by the battery manufacturer
- H. Determine the voltage of the battery by referring to the engine or battery owner's manual and make sure that the 12V/24V select jumper is set to the correct voltage.

---

## 2. CHARGER LOCATION

Do not set a battery or any other object on top of the charger. This will obstruct the ventilation openings and cause excessive heating. Ensure the charger is protected from blowing or dripping water.

---

## 3. GROUNDING INSTRUCTIONS

This battery charger should be connected to a grounded, metal, permanent wiring system; or an equipment grounding conductor (earthing conductor) should be run with the circuit conductors and connected to the equipment grounding terminal in the charger. This terminal is marked with the ground symbol. Connections to the battery charger should comply with all local codes and ordinances.

**4. NEUTRAL CONNECTION**

The grounded circuit conductor (neutral) should be connected to the terminal marked “N” on the input terminal block, TB1.

**5. WIRE RATINGS**

- A. All conductors should be rated for use at 90° C or higher.
- B. All input and output conductor sizes should be coordinated with the fault protection devices: 10A on AC input (14 AWG, 2.5 mm<sup>2</sup> typical), 30A on DC output (10 AWG, 6.0 mm<sup>2</sup> typical). 1 A on Alarm terminal block (20 AWG, 0.5 mm<sup>2</sup> typical).
- C. *Before installation*, ensure adequate battery to charger wire gauge. Wire gauge that is too small may activate the open battery detector and the charger will shut down. The maximum allowed resistance seen by the charger is found in TABLE 1. These figures already include an allowance for charger variations (they are 80% of the typical trip-point) and are for the complete circuit: total of battery leads, battery's internal resistance, and any external equipment. The total resistance seen by the charger must not exceed the following values:

**TABLE 1**

	<b>12V</b>	<b>24V</b>
<b>Maximum Resistance</b>	58mΩ	116mΩ

- D. To determine the appropriate cable and length, please refer to the following table:

**TABLE 2**

<b>Wire Size</b>		<b>Resistance per Foot</b>	<b>Maximum Charger to Battery Distance (Ft.)</b>		<b>Recommended Charger to Battery Distance (Ft.)</b>	
<b>AWG</b>	<b>mm<sup>2</sup></b>	<b>mΩ/Ft.</b>	<b>12V</b>	<b>24V</b>	<b>12V</b>	<b>24V</b>
10	6.0	1.00	25	50	10	19
8	10	0.63	40	79	15	30
6	16	0.40	63	126	24	48

The above lengths consider the resistance of the battery and cables only and do not take into account any additional interconnects.

The above lengths are for operation at 25C. For high temperature installations (40C) reduce lengths by 10%.

In the case of high resistance in the cables to the battery the charger Battery Fault LED may flash (approximately once every 60 seconds). Cable runs exceeding the proper length for the cable gauge used most often cause this problem. The appropriate solution is to change the cable gauge to properly correspond with the necessary cable length (see TABLE 2). In some cases where the resistance is not too far above maximum, the charger may recover after some time (approximately 10 minutes) and start charging the batteries. If it is not possible to decrease the system resistance the Battery Fault feature can be disabled. Please contact SENS at 1-800-742-2326 for further information.

- E. Refer to local electrical codes for additional requirements.
- F. See Section 10 for Terminal Block wire ranges.

**6. FUSE RATINGS**

- A. CAUTION: For continued protection against risk of fire, replace only with same type and rating of fuse.
- B. DC Output Fuse – SENS part number 304530. Bussman Type BK/ATC-30, or Littelfuse 257030 [ATO30], 30A, 32V, fast acting, blade type automotive
- C. AC Input Fuse – SENS part number 304473. Bussman Type BK/AGC-10, 10A, 250VAC, fast acting, ferrule type cylindrical, ¼” X 1-¼”

---

## 7. MOUNTING LOCATION

- A. See the safety instructions for important information concerning the charger location.
- B. The charger should be installed in a sheltered area, protected from rain and snow.
- C. The charger should not be located where temperatures are expected to be colder than -20° C, or hotter than +40° C for operation at rated output current.

**WARNING:**

**NEVER CHARGE STORAGE BATTERIES AT TEMPERATURES ABOVE OR BELOW THE LIMITS SPECIFIED BY THE BATTERY MANUFACTURER. NEVER ATTEMPT TO CHARGE A FROZEN BATTERY.**

- D. Allow sufficient room for routing the fixed wiring to the charger. AC input enters the left side; DC output and alarms exit on the right.
- E. Leave clear space for ventilation all around the unit: at least 6 inches (15 cm) at the top and bottom; at least 2 inches (5 cm) on the sides.
- F. Charger should be mounted on a flat vertical surface so that the chassis does not warp when tightened to the wall.
- G. The charger should be mounted vertically, with the input and output terminal blocks lowermost.

**WARNING:**

**OTHER MOUNTING ORIENTATIONS INTERFERE WITH PROPER VENTILATION AND MAY CAUSE THE CHARGER TO OVERHEAT.**

- H. Do not mount the charger over any heat generating equipment.
- I. Minimize vibrations that the charger will be subjected to.

---

## 8. STATIC DISCHARGE PRECAUTIONS

The printed circuit board contains static sensitive components. Damage can occur even when static levels are too low to produce a noticeable discharge shock. To avoid static discharge damage:

- A. Handle the charger by the chassis only. Remove the cover only when access is essential for installation and service, and replace it promptly when finished.
- B. If possible, wear an approved static protection strap. If one is not available, touch one hand to the chassis before contacting any other part of the charger.

---

## 9. MOUNTING PROCEDURES

**WARNING:**

**THIS CHARGER IS INTENDED FOR COMMERCIAL AND INDUSTRIAL USE. ONLY TRAINED PERSONNEL WHO ARE QUALIFIED TO PERFORM ELECTRICAL INSTALLATIONS SHOULD INSTALL OR SERVICE THIS UNIT.**

The charger mounts to a wall or other vertical support. The mounting surface must safely support the charger's weight, which is 25 pounds (11.3 kg), and also the weight of the fixed wiring.

Mounting on a concrete surface:

- All mounting hardware is provided by the installer.
- Use optional ¾ inch thick, 18 in. x 24 in. sheet of marine plywood (not provided) to provide a suitable mounting surface for the charger.
- Drill four holes to secure the plywood to the wall using a minimum of four ¼ in. drive pin type expansion anchors to secure the plywood to the wall. Secure the plywood to the wall.
- Drill four holes using the mounting diagram on pg. 4 for ¼ in. (or M6) draw nut type expansion anchors through the plywood into the cement wall.
- Insert the four draw nut type expansion anchors through the plywood into the cement wall.
- Mount charger to draw nut type expansion anchors with nuts and flat washers.

Mounting on a drywall:

- Use 3/4 in. thick plywood to span two vertical support members in the wall. The plywood sheet normally does not have to be more than 2 ft. by 2 ft. square.
- Place plywood to avoid electrical wiring, plumbing, etc., concealed behind wall.
- Secure the plywood to the vertical support members using 1/4 in. by 2 in. lag bolts and flat washers in a minimum of four places.
- Mark four holes on the plywood using the mounting diagram on pg. 4. Drill pilot holes into the plywood to secure the mounting bolts.
- Mount charger using four 1/4 in. by 1/2 in. or M6 lag bolts and flat washers.

Mounting on a metal surface:

- Mount charger using four 1/4 -20 by 3/4 in. hex head bolts, flat washers and split lock washers or M6 fastening hardware suitable to attach the battery charger to a frame, panel or cross member in four places. Use the mounting diagram on pg. 4 to place the pilot holes, if needed.
- Tighten all bolts to recommended torque of 45-50 inch pounds.

**10. WIRING**

- A. All wiring must comply with applicable codes and local ordinances. See Section 5 for recommended gauges.
- B. The charger contains a DC output fuse for *internal* fault protection, but this will not protect the DC wiring from fault currents available *from the battery*. **CONSULT NATIONAL CODES AND LOCAL ORDINANCES TO DETERMINE IF ADDITIONAL BATTERY FAULT PROTECTION IS NECESSARY IN YOUR INSTALLATION**

**WARNING:**  
**ENSURE THAT AC POWER IS DISCONNECTED AT THE CIRCUIT BREAKER OR OTHER SAFETY DISCONNECT BEFORE WIRING THE CHARGER.**

- C. Connect the equipment grounding conductor (earthing) to the charger’s grounding terminal. This should always be the first wire connected and the last wire disconnected.
- D. Connect the DC output conductors to TB3. Make the connections in the order shown in Figure 2A (negative ground) or Figure 2B (positive ground). The terminals accept 14 through 6 AWG (2.5 through 16 mm<sup>2</sup>) conductors.

**CAUTION:**  
**OBSERVE POLARITY. THE POSITIVE CHARGER OUTPUT TERMINAL IS LABELED “+” AND THE NEGATIVE TERMINAL IS LABELED “-”.**

**FIVE ALARM MODEL SHOWN- SEE PAGE 3 FOR MODEL NUMBER BREAKDOWN**

**WARNING:**  
**BE SURE TO ROUTE DC POWER WIRING AT LEAST 1/4 INCH (6.3 MM) AWAY FROM AC WIRING, ALARM WIRING, AND THE CIRCUIT BOARD.**

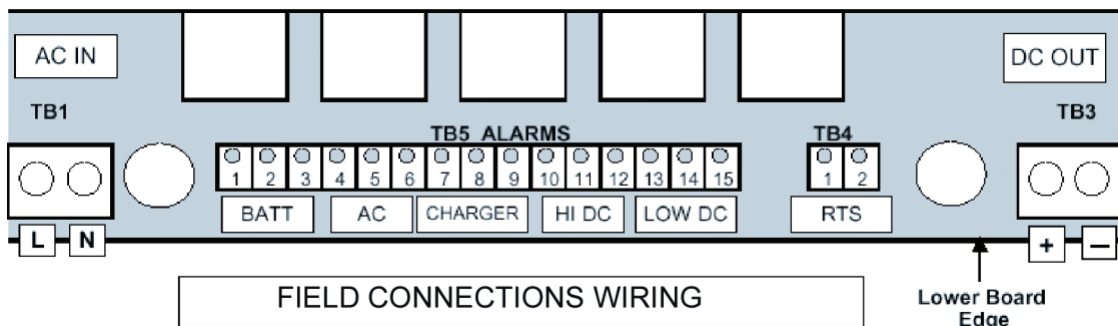

**ONE ALARM MODEL  
SHOWN - SEE PAGE 3  
FOR MODEL NUMBER  
BREAKDOWN**

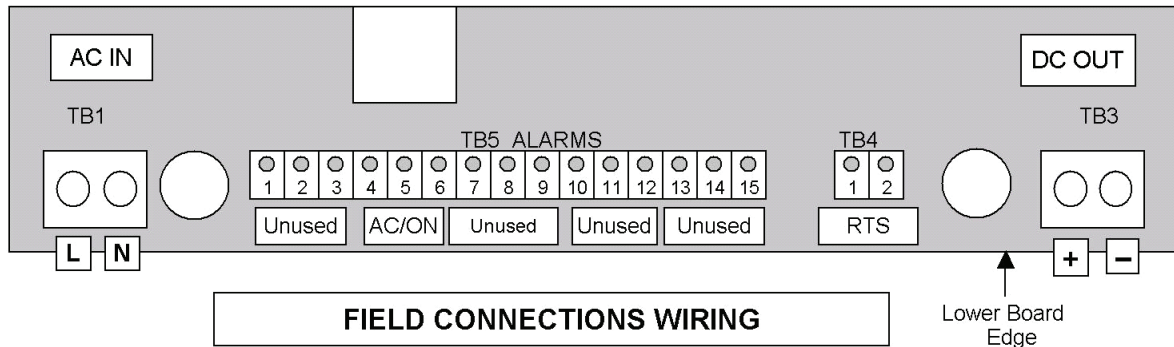

**FIGURE 2A**

**FIGURE 2B**

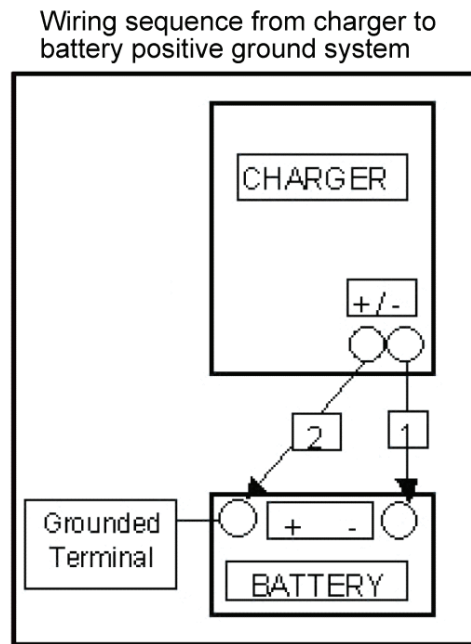
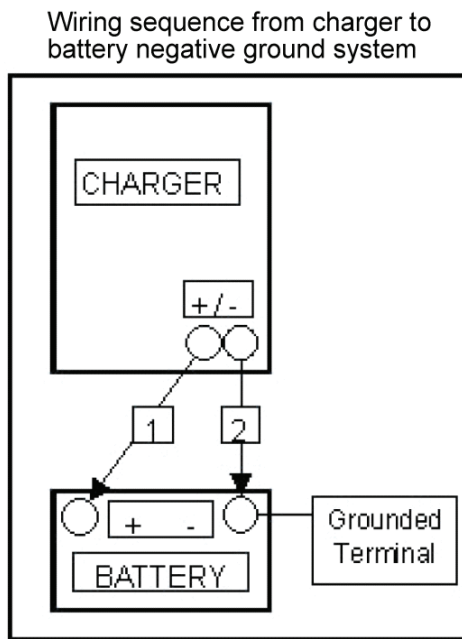

- E. Connect the AC line and neutral conductors at TB1. If there is an identified grounded circuit conductor (neutral), attach it to the terminal marked N. TB1 will accept 14-6 AWG (2.5-16 mm<sup>2</sup>) conductors.

**WARNING:**  
**BE SURE TO ROUTE ALL AC WIRING AT LEAST ¼ INCH (6 MM) AWAY FROM DC WIRING, ALARM WIRING, AND THE CIRCUIT BOARD.**

- F. If the optional alarms are used, connect the alarm wiring to their respective terminals on TB5. Route alarm wiring through the plastic bushing below TB5, keeping the conductors at least ¼ inch (6 mm) away from DC wiring, AC wiring, and the circuit board. The terminals accept 24-16 AWG (0.25-1.5 mm<sup>2</sup>) conductors.

**WARNING:**  
**CONNECT ALARM TERMINALS ONLY TO LOW VOLTAGE, LIMITED ENERGY (“CLASS 2”) CIRCUITS. ALARM CIRCUITS ARE RATED 2A AT 30 VDC, 0.5A AT 125 VAC, MAXIMUM SWITCHING CAPACITY 62.5VA, 60W.**

**FIVE ALARM MODEL**

RELAY CONTACTS	BATTERY FAULT ALARM	AC FAIL ALARM	CHARGER FAIL ALARM	HIGH BATTERY ALARM (HI DC)	LOW BATTERY ALARM (LO DC)
Common	TB5-1 COM	TB5-4 COM	TB5-7 COM	TB5-10 COM	TB5-13 COM
OPEN ON ALARM	TB5-2 OK	TB5-5 OK	TB5-8 OK	TB5-11 OK	TB5-14 OK
CLOSE ON ALARM	TB5-3 FAIL Defaults to OK with no AC input	TB5-6 FAIL Defaults to Fail with no AC input	TB5-9 FAIL Defaults to OK with no AC input	TB5-12 FAIL Defaults to OK with no battery	TB5-15 FAIL Defaults to fail with no battery

**ONE ALARM MODEL**

RELAY CONTACTS	Not Used	MASTER ALARM	Not Used	Not Used	Not Used
Common	TB5-1 No Connection	TB5-4 COM	TB5-7 No Connection	TB5-10 No Connection	TB5-13 No Connection
OPEN ON ALARM	TB5-2 No Connection	TB5-5 OK	TB5-8 No Connection	TB5-11 No Connection	TB5-14 No Connection
CLOSE ON ALARM	TB5-3 No Connection	TB5-6 FAIL Defaults to Fail with no AC input	TB5-9 No Connection	TB5-12 No Connection	TB5-15 No Connection

- G. If the optional remote temperature sensor is used:
- Remove the internal sensor at TB4, if it is present.
  - Locate the remote sensor where it will accurately detect the battery temperature.
  - Connect the remote sensor leads to TB4. The sensor is not polarized, so it does not matter which lead connects to terminal #1.
  - Route sensor wiring through the plastic bushing below TB5, keeping the conductors at least ¼ inch (6 mm) away from DC wiring, AC wiring, and the circuit board.

- H. Verify that all connections are secure and in the proper locations. Tighten all unused screws on the terminal blocks to secure them against vibration.
- I. Ensure all wires are routed so the cover will not pinch them.

## 11. INTERNAL ADJUSTMENTS

**WARNING:**  
**MAKE SURE THE AC POWER TO THE CHARGER IS SHUT OFF WHILE MAKING THE FOLLOWING ADJUSTMENTS.**

AC line voltage switch  
 110-120V: Use 115V position  
 208-240V: Use 230V position

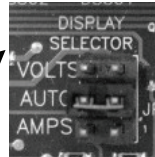

Meter Display Jumper JP800. Choose VOLTS, AMPS, or AUTO for meter display view.

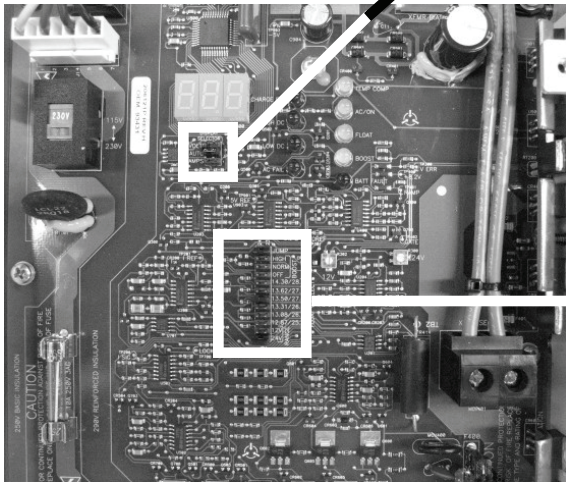

“Jump start” battery initialization mode

Jumper JP1. Configure battery and output voltage settings.

Automatic boost jumper  
 Use NORM setting for fast charge. Use Off setting for float charge

Float voltage jumper  
 Set according to battery supplier's specifications

Battery range jumper  
 (12V or 24V battery)

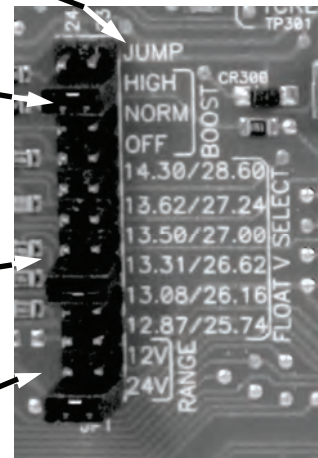

**SAME FOR ALL MODELS**

- A. Set the AC voltage select switch (SW100) according to the line voltage. Use the 115V position for nominal mains voltages between 110V and 120V. Use the 230V position for nominal mains voltages between 208V and 240V.
- B. Set the battery range jumper (JP1A) according to nominal battery voltage. Use the 12V position for 12V batteries. Use the 24V position for 24V batteries.
- C. Set the boost mode jumper (JP1B) according to whether the battery should have automatic boost charging. If the battery manufacturer recommends boost charging (equalization) use the NORMAL position. If not, use the OFF position.
- D. Set the float voltage select jumper (JP1C) according to the battery manufacturer's recommended 25°C float voltage. The settings are:
  - 14.30/28.60 for 10 or 20 cell Nickel Cadmium at 1.43V/cell
  - 13.62/27.24 for 6 or 12 cell (VRLA) lead-acid at 2.27V/cell, and for 19 cell Nickel Cadmium at 1.43V/cell
  - 13.50/27.00 for 6 or 12 cell (VRLA or high capacity) lead-acid at 2.25V/cell, and for 19 cell Nickel Cadmium at 1.42V/cell
  - 13.31/26.62 for 6 or 12 cell (flooded) lead-acid at 2.22V/cell, and for 19 cell Nickel Cadmium at 1.40V/cell
  - 13.08/26.16 for 6 or 12 cell lead-acid at 2.18V/cell
  - 12.87/25.74 for 9 or 18 cell Nickel Cadmium at 1.43V/cell

- E. Set the Display Selector jumper to one of the 3 available positions on JP800 (see photograph previous page):
- VOLTS – Place the short jumper in the “upper” position next to the word “VOLTS”. The 3-digit LED meter display will show DC Volts only
  - AUTO – Place the short jumper in the center position next to the word “AUTO”. The 3-digit LED meter display will automatically and continuously alternate between DC Amps and DC Volts. The display shows DC Amps for approximately 6 seconds and DC Volts for approximately 3 seconds.
  - AMPS – Place the short jumper in the “lower” position next to the word “AMPS”. The 3-digit LED meter display will show DC Amps only.

**WARNING:**

**USE ONE JUMPER ONLY ON THE DISPLAY SELECTOR JP800. USE ONLY THE “SHORT” JUMPER PROVIDED FOR JP800, TO AVOID INTERFERENCE WHEN REPLACING THE COVER (“TALL” JUMPERS ARE TO BE USED ONLY ON JP1).**

- F. The JUMP position allows initial charging of Nickel Cadmium batteries, or new lead acid batteries supplied from the manufacturer dry and discharged, from a zero charge state. The JUMP feature can also be used when recharging excessively discharged batteries already in service. To initially charge/commission zero charge batteries, place a jumper (spare provided with charger) in the JUMP position on JP1. Operate the charger long enough to retain more than 1.5V/cell for lead acid and 1.0V/cell for nickel cadmium batteries or until the charger returns to FLOAT MODE (FLOAT MODE LED will be green). See SENS Application Note 10 to finish fully commissioning the batteries, as using the JUMP feature alone is not sufficient. Once the batteries are fully charged, the jumper may be removed or left in the JUMP position permanently. The jumper may remain in the JUMP position permanently to ensure that the charger is able to recharge very low or dead batteries. If battery voltage is below 9V (12V system) or 18V (24V system) when AC power is restored and the JUMP feature is not activated, the charger will go into Battery Fault (alarm state that disables charger). In this situation the charger will not charge the batteries. If the JUMP feature is enabled when AC power is restored, the charger will begin charging. Depending on the battery state of charge, the charger may go into Battery Fault and remain so for some period of time (generally 12 – 24 hours) while the batteries are slowly charged. The Battery Fault LED will cycle (approximately once every minute) during this time. Once Battery Fault stops cycling, the charger will return to FLOAT or BOOST MODE as normally demanded.

**WARNING:**

**USE THE JUMP FEATURE ONLY WITH LIQUID ELECTROLYTE NICKEL-CADMIUM BATTERIES, OR WITH RECENTLY FILLED NEW LEAD ACID BATTERIES SUPPLIED FROM THE MANUFACTURER DRY AND DISCHARGED. WHILE THE JUMP FEATURE MAY BE USED TO CHARGE EXCESSIVELY DISCHARGED LEAD ACID BATTERIES THAT HAVE ALREADY BEEN IN SERVICE, CONSULT THE BATTERY MANUFACTURER TO DETERMINE IF AND HOW THEY CAN SAFELY BE RESTORED TO SERVICE.**

**WARNING:**

**LEAVING A JUMPER IN THE JUMP POSITION DISABLES THE BATTERY VOLTAGE INTERLOCK, WHICH INCREASES THE RISK OF ACCIDENTALLY OVERCHARGING 12V BATTERIES WITH 24V SETTINGS. INCORRECT CHARGE VOLTAGE WILL ACCELERATE GENERATION OF EXPLOSIVE GASES, INCREASING THE RISK OF FIRE OR EXPLOSION.**

- G. Replace the cover by sliding it straight onto the charger. Ensure the cover’s locating tabs engage the slots in the chassis. Secure the cover with its four mounting screws.

## 12. CHECK OUT

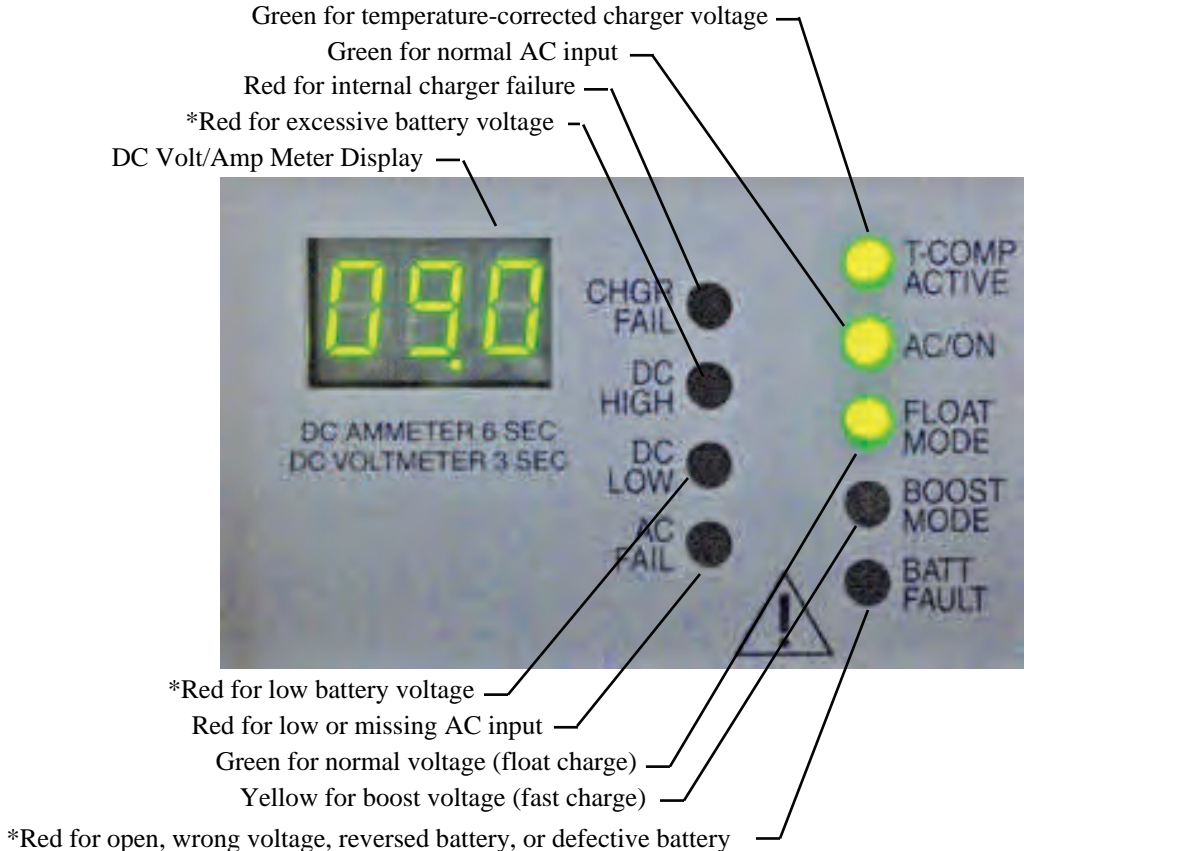

\* Active only on five alarm models - see page 3 for model number breakdown

### See OPERATOR INSTRUCTION section for LED indicator definitions:

- A. Verify the status LEDs:
  - **AC FAIL** should be **ON**. If not, the DC output may be open or reversed, or the battery may be extremely discharged.
  - **BATT FAULT** should be **OFF**. If it lights, check for reversed polarity of the DC wiring.
  - The **DC LOW** (Low Battery) LED may be either on or off, depending on the battery's state of charge.
  - All other LEDs and the meter display should be off.
  - If the **DC HIGH** LED is on, check battery voltage jumper setting.
- B. Apply AC power by closing the branch circuit breaker and any other disconnect devices.
- C. The meter display should light immediately after power on. The green **AC/ ON** LED should be lighted. If a temperature sensor is present, either internal or remote, the green **T-COMP** (Temperature Compensation) LED should be lighted.
- D. If the **BATT FAULT** LED lights when AC is applied, this indicates that the battery voltage does not agree with the **Range** jumper setting. The charger is interlocked, and will not operate in this condition. Disconnect AC power, then correct the jumper setting or battery voltage before proceeding.
- E. After a short delay (typically 10 seconds or less), the charger will produce output.
- F. If the meter display jumper is selected to read Amps or automatic Volts/Amps:
  - Current should be close to 10A if the battery requires recharging. If automatic boost is enabled, the **BOOST MODE** LED may light, in which case the battery will be charged until it reaches 106% of the float voltage. If boost is disabled, the green **FLOAT MODE** LED should be on and the battery will charge until it reaches the float voltage setting.
  - Output current will be low if the battery is fully charged, possibly too low to read on the meter. This is normal, provided the correct charging voltage is present. The green **FLOAT MODE** LED should light when output current is below approximately 9 A (5A for single alarm).

## OPERATOR INSTRUCTIONS

**WARNING:**  
**NO OPERATOR SERVICEABLE PARTS INSIDE.**  
**DO NOT OPEN. COVER MUST BE IN PLACE DURING USE.**  
**USE THIS CHARGER FOR CHARGING LEAD-ACID OR NICKEL-CADMIUM BATTERIES ONLY.**

### A. ADVANCED DESIGN FEATURES

#### Battery Friendly:

- Float and boost voltage selectable at install per specific battery vendor recommendations.
- Remote temperature compensation for most accurate float and boost voltage control.
- Able to charge a dead battery.
- Float and Boost voltage electronically controlled with a 4-rate fast charge program. See chart below.

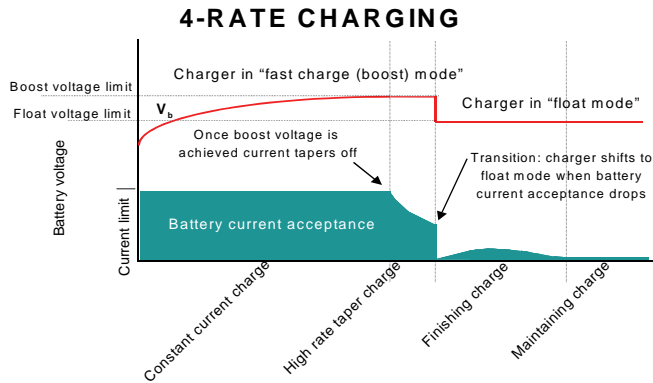

#### Temperature Compensation:

- The battery charger is temperature compensated to match the negative temperature coefficient of the battery. Thus, the output voltage will increase slightly as the temperature decreases and decrease as temperature increases.
- The output voltage is clamped at 0 and +40 Degrees C to protect against extremely high or low output voltage. See chart below.

#### AUTOMATIC TEMPERATURE COMPENSATION

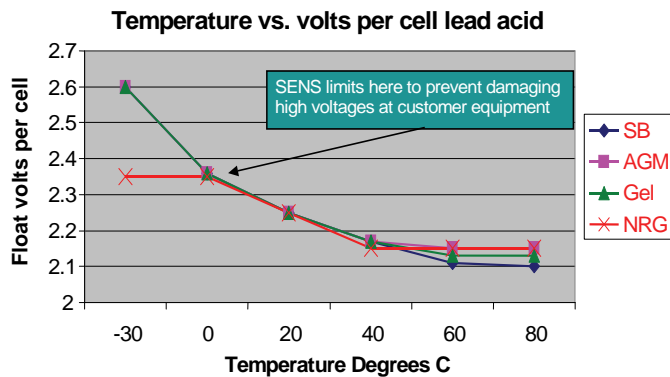

#### Fault Tolerant:

- The charger is protected from the following faults:
- Internal power component failures.
  - Over heating (over temperature output power reduction).
  - Protected against power line transients and surges.

#### Battery Fault Protection and Alarm:

- The battery charger automatically checks the battery voltage before power-on startup. If the battery volt-

age is either too high or too low, the charger enters a “lockout” period for approximately 10 seconds before attempting an automatic restart.

- The “JUMP” feature (described in Section 11-F in this manual) may be used to allow the battery charger to override the lockout and start charging a low-voltage discharged battery.
- The battery charger will not start if the battery or battery cables have a short circuit, and will start automatically with a good battery if the short circuit is removed.
- In addition to detecting low battery voltage and short circuits, the battery charger also monitors the peak voltage at its DC output terminals and will enter lockout if the DC cable resistance is too high or if the battery’s internal resistance is too high.
- If a battery is connected backwards, this reverse polarity condition will keep the battery charger in lockout and it will remain in lockout until the battery is disconnected. A reverse polarity condition will not blow a fuse; the battery charger will start and run normally when a good battery is connected with correct polarity.
- Whenever one of these fault conditions triggers the battery fault protection circuitry as described above, the “Batt Fault” relay and LED are both activated.
- If polarity is correct, DC cables OK, and the “JUMP” feature attempted, the battery fault alarm most likely indicates a defective battery. Replace with a new battery.

**Robust Hardened Construction:**

- Shock and Vibration tested to UL 991, 2G.
- Shock and Vibration tested to UL 991, 5G option available.
- Lightning transient immunity to ANSI/IEEE C62.41 Cat. B and EN 50082-2 heavy industrial.
- Wide operating temperature range: -20 to + 40 Degrees C. Charger will operate at reduced output current rating up to +60 Degrees C.
- Conformal coated printed wiring boards for erosion protection.

**Worldwide Agency Approvals:**

- UL listed, UL 1012, UL 1236.
- CUL listed to CSA C22.2 107.2- M89.
- CE marked for EMC directive (industrial environment) and EN 60335-2-29.
- Worldwide operating voltage and frequency ranges.

**B. FRONT PANEL LED INDICATOR DEFINITIONS AND TROUBLE SHOOTING:**

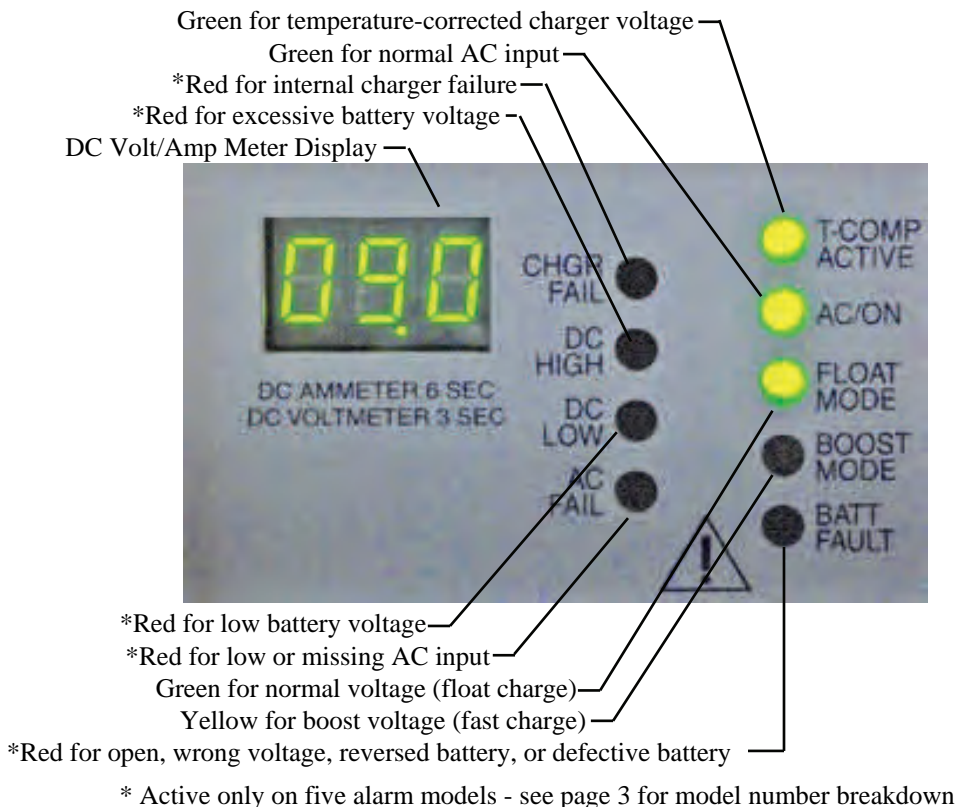

ITEM	TEXT	LED	Meaning	Troubleshooting
1	CHGR FAIL	RED	Charger Fail	Charger unable to provide charging current to battery. Replace unit. AC input voltage is too low to supply proper current when load is applied. Control board is damaged and should be re-
2	* DC HIGH	RED	Battery DC Voltage High	Check that the battery range voltage jumper setting agrees with battery used. High battery alarm voltage is 17v for 12v system
3	DC LOW	RED	Battery DC Voltage Low	Check that battery range voltage jumper setting agrees with battery used. Check for defective battery. Check DC load. Low battery alarm voltage is 12v for 12v system
4	AC FAIL	RED	Input AC Missing	Check AC input voltage to charger. Have qualified installer check AC line voltage switch setting. Setting must agree with AC voltage at site. Check AC fuse.
5	T-COMP	GREEN	On if Temperature Compensation Working, Off if Temperature Compensation Option not used.	Confirm if temperature compensation is intended to be used. Only one sensor (Local or remote) should be connected.
6	AC/ ON	GREEN	1 alarm model: Charger operating normally 5 alarm model: AC input good	Should be on in normal use. 1 alarm model: If LED is OFF, AC FAIL, CHGR FAIL or BATT FAULT LED should be ON. 5 alarm model: If LED is OFF, AC FAIL should be ON.
7	FLOAT MODE	GREEN	Charger Output in Float Mode	If the automatic boost jumper is in the OFF location, this LED will always be on. If the automatic boost jumper is in the "NORM" location, this LED will come on after the battery
8	BOOST MODE	AMBER	Charger Output in Boost Mode	This LED will not be on if the automatic boost jumper is in the OFF location, or if the automatic boost jumper is in the "NORM" location and the battery is nearly fully charged up.
9	BATT FAULT	RED	Battery Fault-Charger automatically disabled:	<ul style="list-style-type: none"> <li>• Battery reversed.</li> <li>• High resistance in charger leads (leads too small, too long , poorly connected, open).See Section 5 for information on wire length and gauge.</li> <li>• Battery internal open circuit.</li> <li>• Battery voltage does not match charger voltage range</li> <li>• Defective Battery, replace with new battery</li> </ul>

\* Active only on five alarm models - see page 3 for model number breakdown

**TROUBLESHOOTING GUIDE—REPEATED BLOWN AC FUSE**

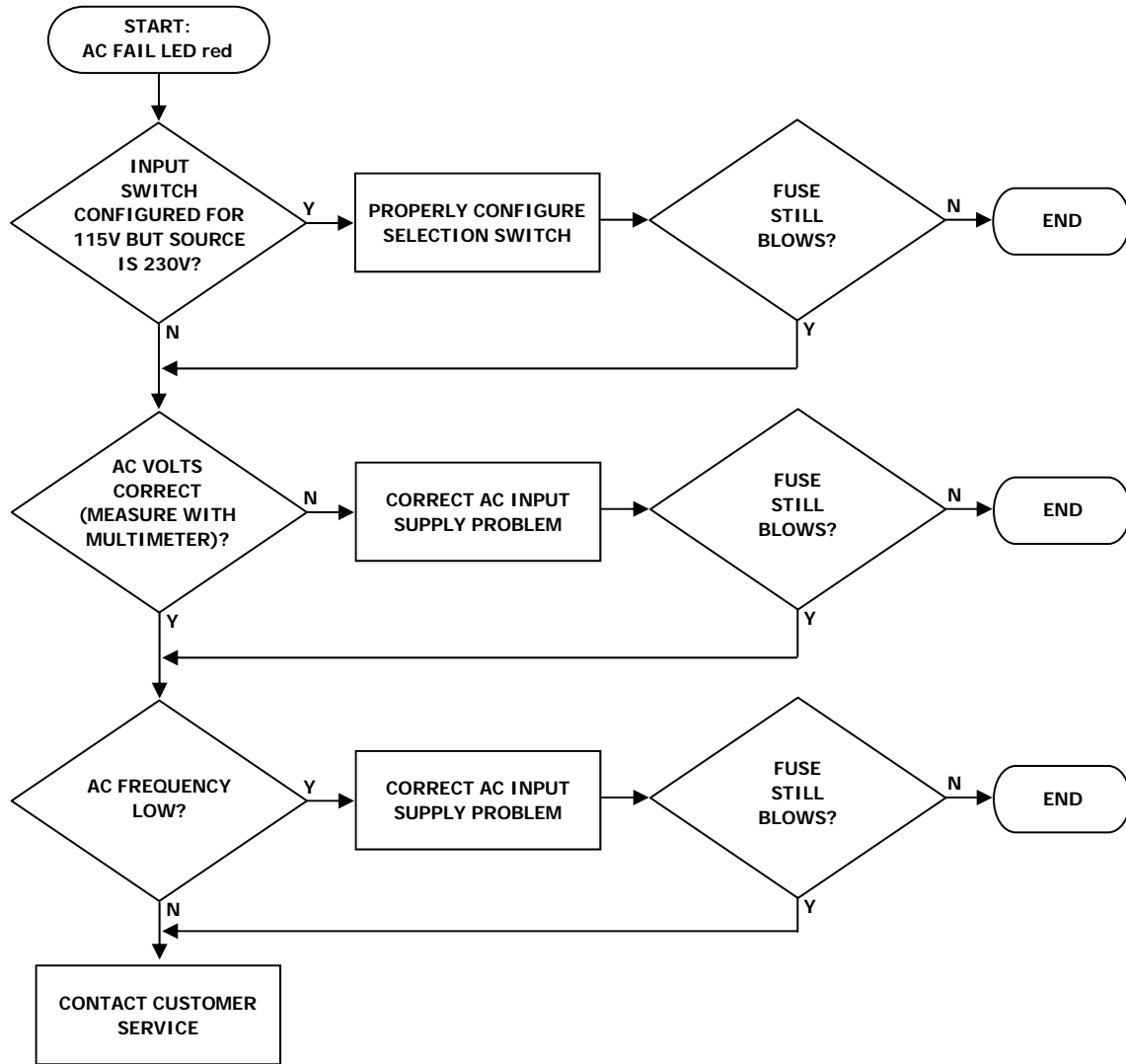

**TROUBLESHOOTING GUIDE—AC FAIL ALARM**

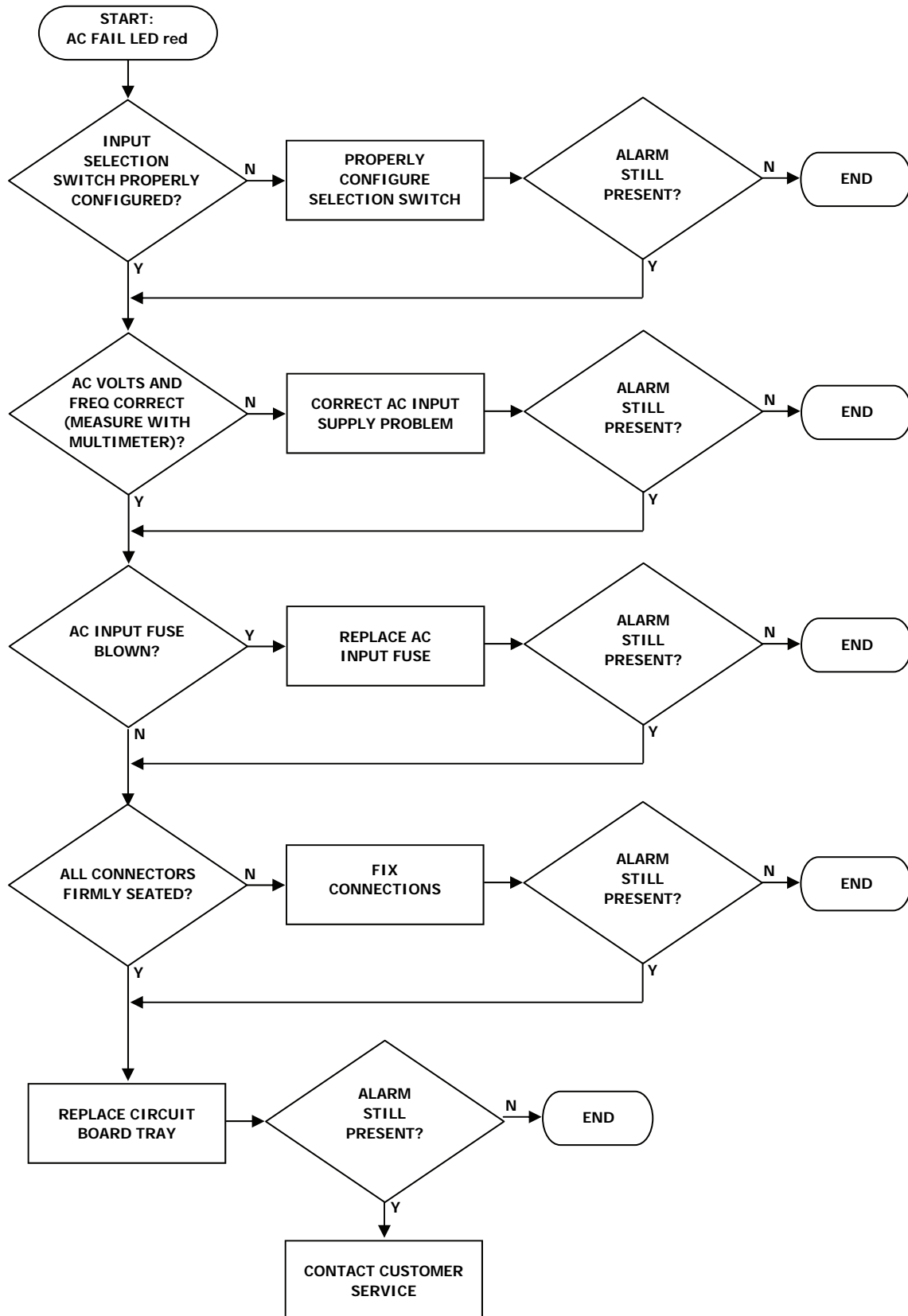

**TROUBLESHOOTING GUIDE—CHARGER FAIL ALARM**

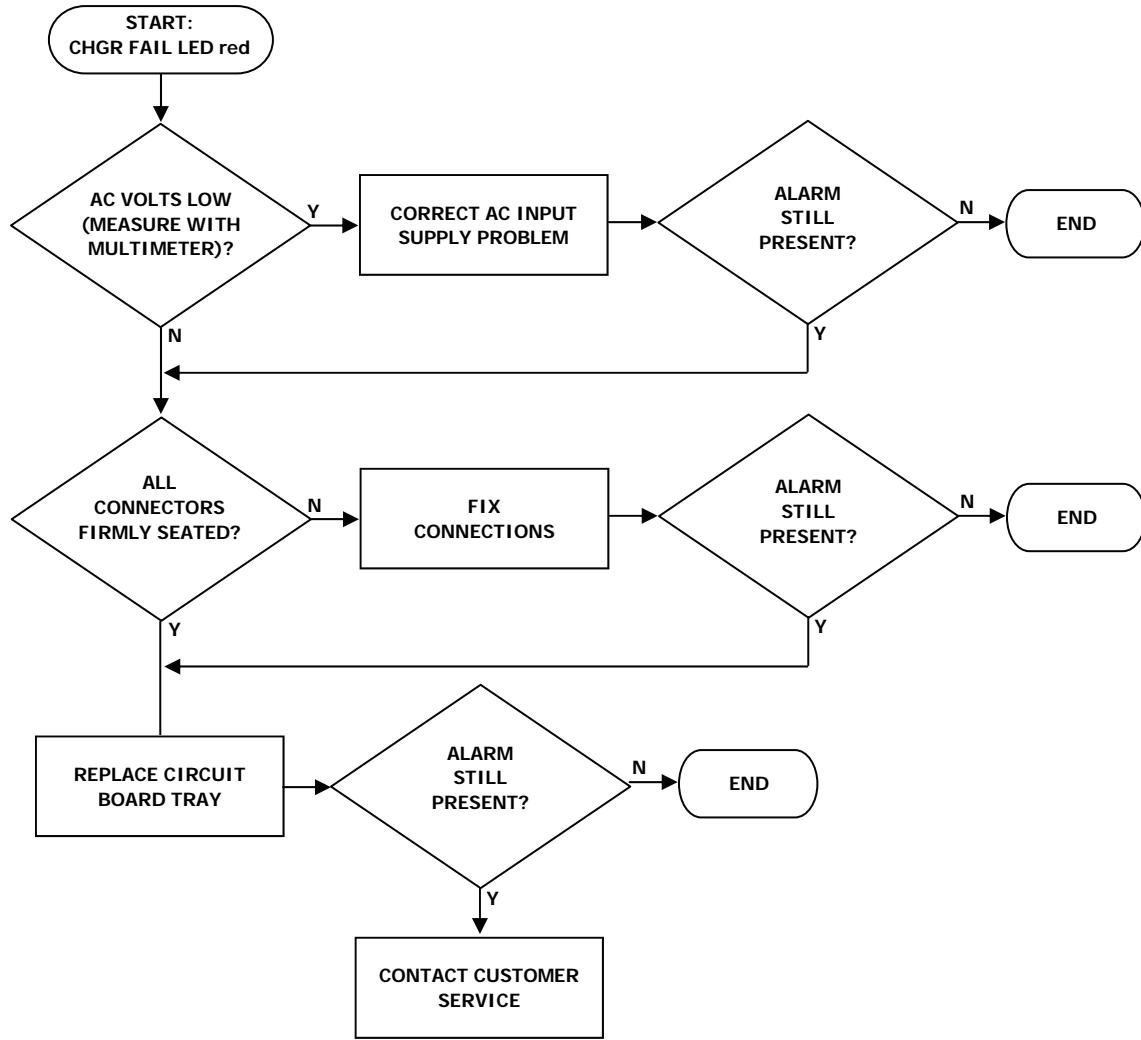

**TROUBLESHOOTING GUIDE—DC HIGH ALARM**

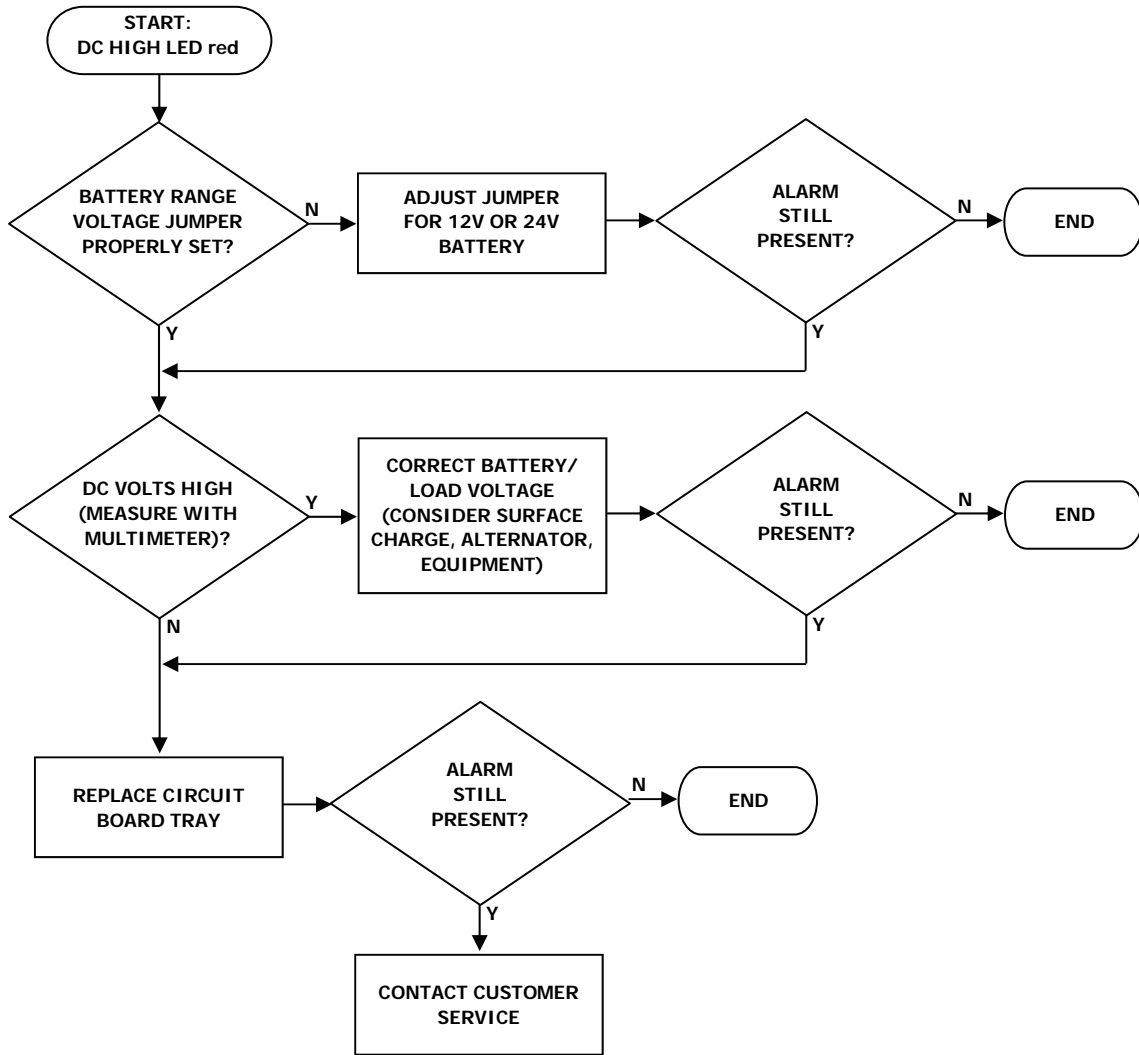

**TROUBLESHOOTING GUIDE—DC LOW ALARM**

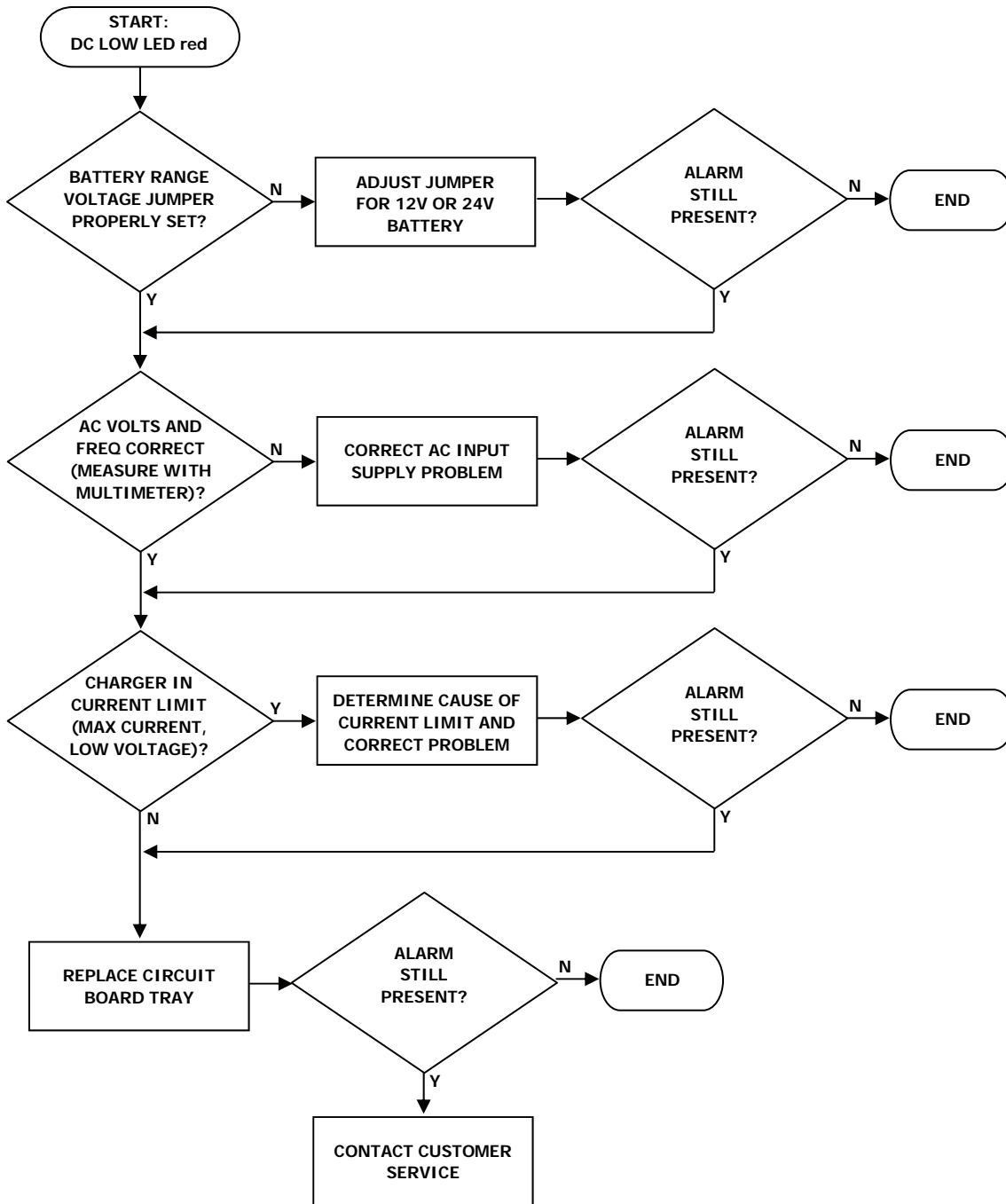

**TROUBLESHOOTING GUIDE—BATTERY FAULT ALARM**

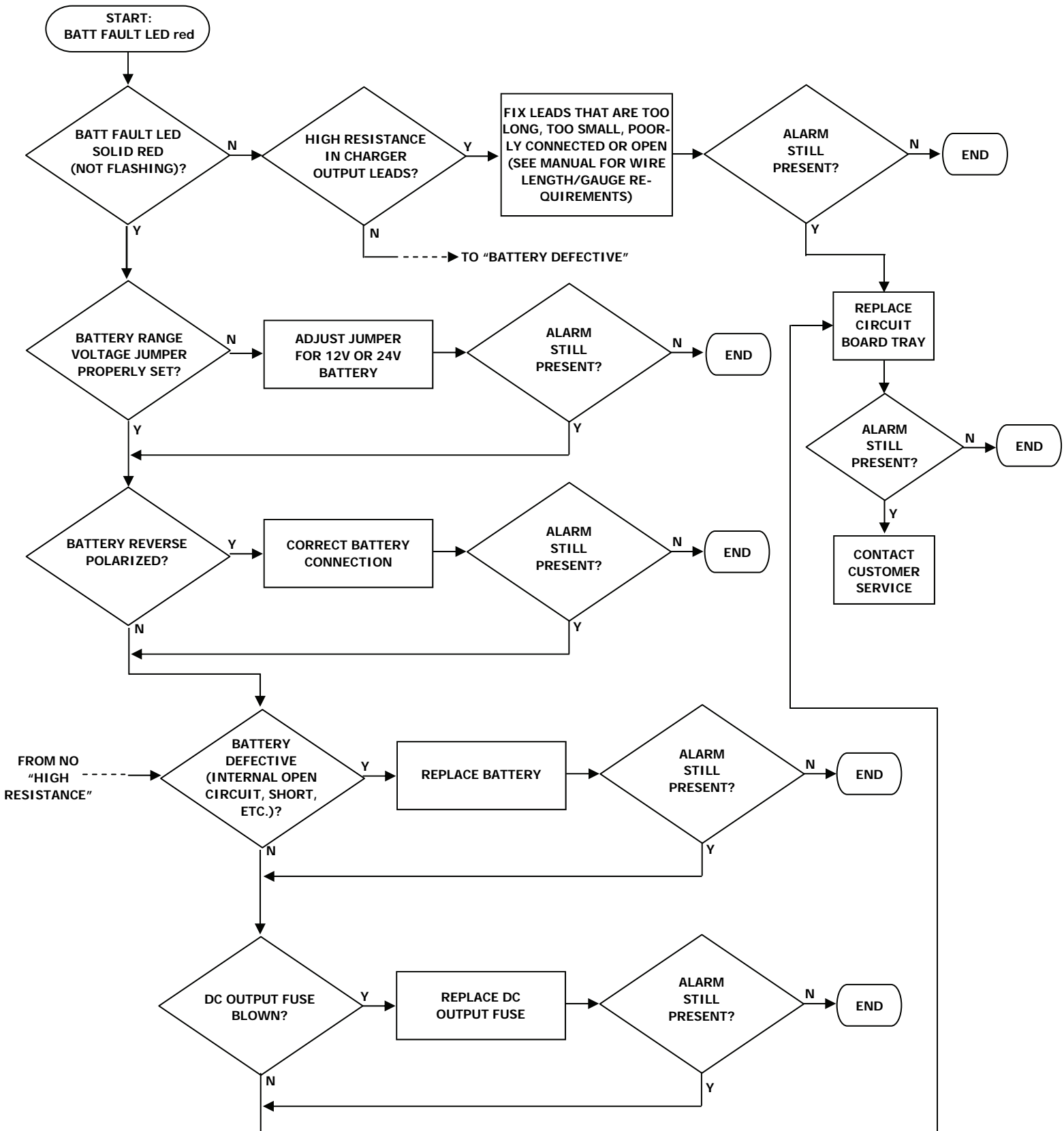

**NORMAL SET UP:**

1. Apply AC power by closing the branch circuit breaker and any other disconnect devices.
2. The meter display should light immediately after power on. The green **AC/ ON** LED should be lighted. If a temperature sensor is present, either internal or remote, the green **T-COMP** (Temperature Compensation) LED should be lighted.
3. After a short delay (typically 10 seconds or less), the charger will produce output. If the meter display jumper is selected to read Volts or automatic Volts/Amps, the voltmeter reading should increase, indicating the battery is being charged.
4. If the meter display jumper is selected to read Amps or automatic Volts/Amps:
  - Current should be close to 10A if the battery requires recharging. If automatic boost is enabled, the **BOOST MODE** LED may light, in which case the battery will be charged until it reaches 106% of the float voltage. If boost is disabled, the green **FLOAT MODE** LED should be on and the battery will charge until it reaches the float voltage setting.
  - Output current will be low if the battery is fully charged, possibly too low to read on the meter. This is normal, provided the correct charging voltage is present. The green **FLOAT MODE** LED should light up when output current is below approximately 9.0 A (5A for single alarm).

**C. ALARM DESCRIPTION, FIVE ALARM MODEL:**

RELAY CONTACTS	BATTERY FAULT ALARM	AC FAIL ALARM	CHARGER FAIL ALARM	HIGH BATTERY ALARM (HI DC)	LOW BATTERY ALARM (LO DC)
COMMON	TB5-1 COM	TB5-4 COM	TB5-7 COM	TB5-10 COM	TB5-13 COM
OPEN ON ALARM	TB5-2 OK	TB5-5 OK	TB5-8 OK	TB5-11 OK	TB5-14 OK
CLOSE ON ALARM	TB5-3 FAIL Defaults to OK with no AC input	TB5-6 FAIL Defaults to Fail with no AC input	TB5-9 FAIL Defaults to OK with no AC input	TB5-12 FAIL Defaults to OK with no battery	TB5-15 FAIL Defaults to fail with no battery

**D. ALARM DESCRIPTION, ONE ALARM MODEL:**

RELAY CONTACTS	Not Used	* MASTER ALARM	Not Used	Not Used	Not Used
COMMON	TB5-1 No Connection	TB5-4 COM	TB5-7 No Connection	TB5-10 No Connection	TB5-13 No Connection
OPEN ON ALARM	TB5-2 No Connection	TB5-5 OK	TB5-8 No Connection	TB5-11 No Connection	TB5-14 No Connection
CLOSE ON ALARM	TB5-3 No Connection	TB5-6 FAIL Defaults to Fail with no AC input	TB5-9 No Connection	TB5-12 No Connection	TB5-15 No Connection

\* The MASTER ALARM is a summary alarm. It will close on CHGR FAIL, AC FAIL or BATT FAULT.

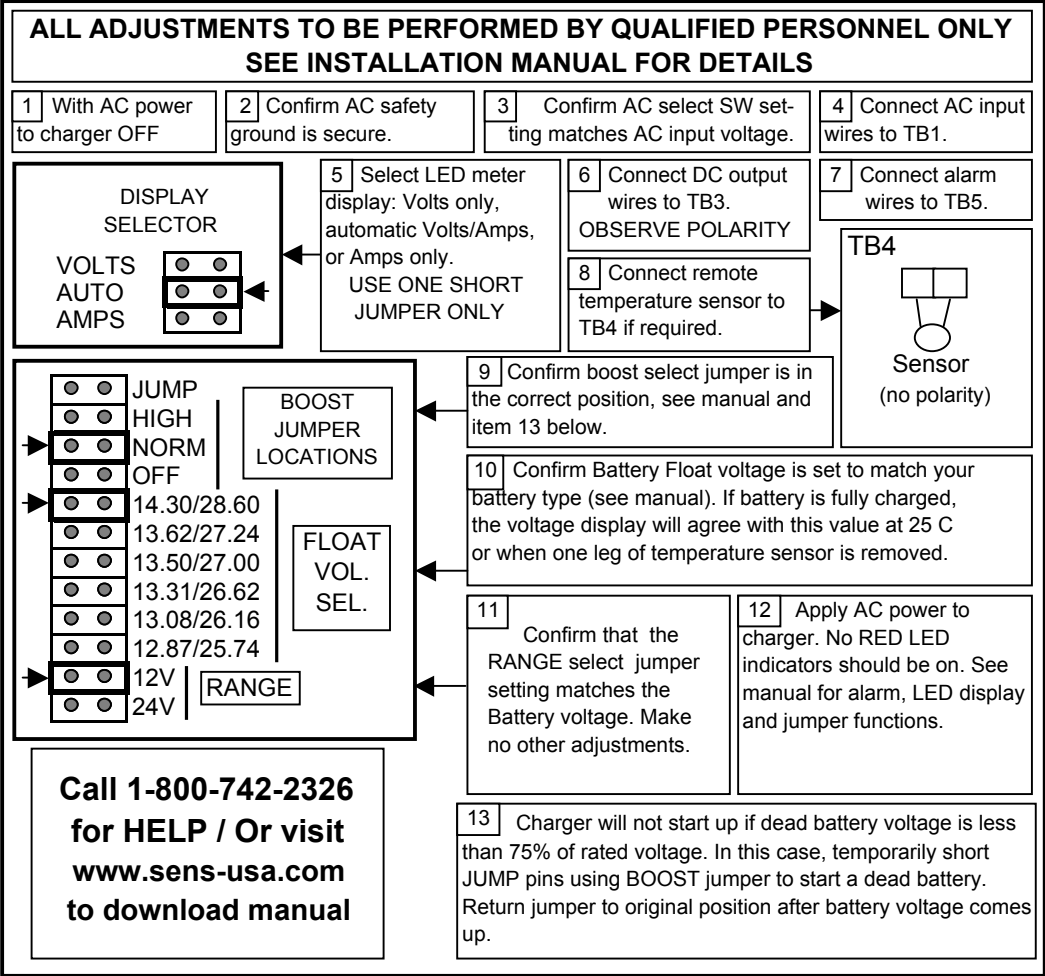

5.00" max

5.00" max

**NOTES:**

1. LETTERING TO BE BLACK INK ON SILVER FOIL LABEL, MATERIAL RATED PER R/C (PGDQ2). LABEL ADHESIVE PROVIDED MUST BE SUITABLE FOR USE ON ALUMINUM & RATED FOR 80 DEG C MINIMUM.
2. PSA MATERIAL IS TO BE PROVIDED WITH RELEASE LINER.
3. RADIUS CORNERS .125" MAXIMUM.
4. THIS DRAWING NOT TO SCALE.



DCN No.	105963		
Drawn By:	HN	Date:	2/7/2011
Approved By:		Date:	
DWG Name:	LABEL, INSIDE COVER, NRG10/20		
PN: 808526	DWG REV.	E	

# STOP!

Verify that all settings shown below are correct *before energizing charger*. **CAUTION:** Correct settings are essential to ensure proper battery performance and long battery life. *Before installation*, ensure adequate battery to charger wire gauge. Wire gauge that is too small may activate the open battery detector and the charger will shut down:

AWG	Recommended Charger to Battery Distance (Ft.)			
	12V/10A	24V/10A	12V/20A	24V/20A
10	10	19	N/A	N/A
8	15	30	7	15
6	24	48	12	24

For runs exceeding the above values, call SENS at 1-800-742-2326 or (303) 678-7500.

## FACTORY SETTINGS

Charger is factory set for the following settings. Change the setting if needed for your battery or site conditions

Input:	208-240 VAC
	120 VAC
Jump:	DISABLED
Fast charge:	ENABLED / OFF
Float voltage:	14.30    28.60
	13.62    27.24
	13.50    27.00
	13.31    26.62
	13.08    26.16
	12.87    25.74
Voltage range:	12-volt    24-volt
	12/24 dual

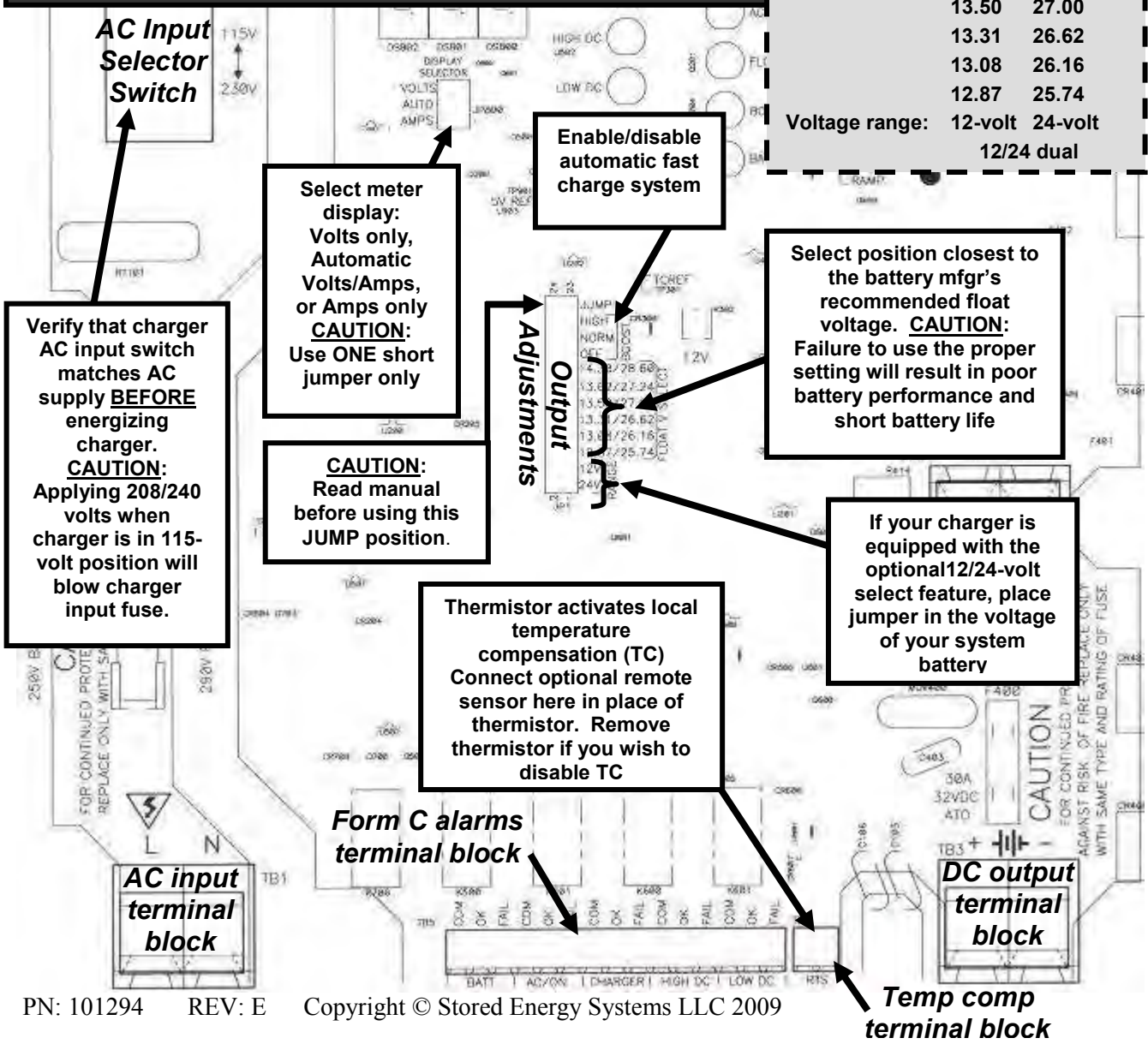



## **SENS Limited Warranty: NRG Series Battery Charger**

### **What is covered?**

This warranty covers any defect in material and workmanship on NRG model battery chargers manufactured by Stored Energy Systems, a Colorado Limited Liability Company (SENS).

### **What this warranty does not cover:**

This warranty does not cover damages, defects or failures of your equipment resulting from shipping damage, accidents, installation errors, unauthorized adjustment or repair, unauthorized third-party service, failure to follow instructions, misuse, fire, flood, acts of persons not in our control, and acts of God.

### **For how long:**

Three years from date of shipment, except magnetic parts and power semiconductors, which are covered for 10 years.

### **What we will do:**

If your battery charger is defective within the warranty period, we will repair it or, at our option, replace it at no charge to you.

If we choose to replace your charger, we may replace it with a new or refurbished one of the same or similar design. The repair or replacement will be warranted for the remainder of the original warranty period. If we determine that your charger cannot be repaired or replaced, we will refund its purchase price to you.

### **What we ask you to do:**

Contact SENS service department to obtain warranty service instructions. To obtain warranty service the product must be returned, freight prepaid, to the factory under a Return Material Authorization (RMA) number provided by SENS. If, in SENS' opinion, the problem can be rectified in the field, SENS may elect to ship replacement parts for customer installation instead of having the product returned to the factory.

### **Limitation:**

This warranty is limited to defects in material or workmanship of the product. It does not cover loss of time, inconvenience, property damage or any consequential damages. Repair, replacement or refund of the purchase price of the equipment is your exclusive remedy.

## **Extended Warranty: NRG Series Battery Charger**

### **Extended Warranty Period**

At any time during the standard Limited Warranty period, customer may purchase extended warranty to lengthen the warranty period on the entire product to 5 or 10 years from date of original shipment. All other terms of SENS Limited Warranty (see above) apply.

## **Premium Warranty: NRG Series Battery Charger**

### **Premium Warranty Coverage**

At the time of original Product purchase, Customer may purchase premium warranty coverage for the standard warranty period or for extended periods of 5 or 10 years from date of original shipment. With premium warranty coverage, SENS will, if requested by Customer, pay reasonable and customary labor and mileage charges for the user to replace or repair the charger, limited to 100% of the Company's original net Product invoice amount, in the form of a credit toward future purchases of Product from the Company. All other terms of SENS Limited Warranty (see above) apply.