

FC/FCA
12, 24, 32 & 48 VOLT, 6 & 10 AMP

BATTERY CHARGER with
Remote Temperature Compensation

OPERATION & MAINTENANCE
GUIDE

SENS part no.:	101233
Document revision:	B
Engineering change no.	105238
Date	6/18/2007



**1840 Industrial Circle,
Longmont, CO 80501
Fax: (303) 678-7504
Tel: (303) 678-7500
Email: servicece@sens-usa.com
Web: www.sens-usa.com**

**Installation or Service problems? Call SENS at (800) 742-2326 between 8:00
A.M. and 5:00 P.M. Mountain time Monday to Friday, or visit our website.**

IMPORTANT SAFETY INSTRUCTIONS

SAVE THESE INSTRUCTIONS

This manual contains important safety and operating instructions for Stored Energy Systems (SENS) model battery charger model FC. Before using the battery charger, read all instructions and cautionary markings on the battery charger, battery and equipment connected to the battery system.

User Manual Conventions

Pay special attention to these three types of notices used in this document.

WARNING: is used in this manual to warn of possible personal or property injury

CAUTION: is used in this manual to warn of possible equipment damage

NOTE: is used in this manual to provide advice on how to obtain maximum performance, reliability or life from components of your system.

WARNING:
Please read these safety warnings and heed them. Failure to do so could result in either severe personal injury or equipment damage.

To reduce the risk of injury, charge only properly sized lead-acid or nickel cadmium batteries. Other types of batteries or under-sized batteries may burst causing personal injury and damage.

- Do not install or operate charger if it has been dropped or otherwise damaged. Return it to the factory for repair.
- Install the charger in accordance with all local codes.
- Do not expose charger to rain or snow.
- Do not disassemble charger; return to factory when service or repair is required. Incorrect assembly may result in a risk of electric shock or fire.
- To reduce risk of electric shock, de-energize and disconnect the AC input and the battery from the charger before attempting maintenance or cleaning.
- Use of an accessory not recommended or sold by SENS may result in a risk of fire, electric shock or personal injury.
- During normal operation, batteries may produce explosive hydrogen gas. *Never smoke, use an open flame, or create sparks near the battery or charger.*
- Remove jewelry, watches, rings, etc. before installing battery or charger.

Maintenance Instructions

User maintenance is limited to charger adjustment. All on-site servicing should be performed by qualified service personnel. If qualified personnel are not available, return the charger to the factory for repair, or contact the factory to arrange for field service.

1
READ THIS
FIRST

CAUTION: Failure to follow installation instructions may cause equipment damage, or void the equipment warranty. READ THESE INSTRUCTIONS BEFORE PROCEEDING!

- The charger *must* be connected to a battery for it to operate properly (see Section 4.1). If the charger is feeding a load and charging a battery, disconnecting the battery will cause the output voltage to rise to unsafe levels with possible damage to connected loads. *Always disconnect the AC mains power before disconnecting the battery from the charger.* If the charger is not connected to a battery it will operate at approximately half its rated voltage, and the alarm relays (if the unit is so equipped) will chatter.
- Do not connect the battery leads to the charger backwards. Doing so will blow the output fuse when the charger is energized
- Changing factory-set potentiometers *voids the warranty.* Contact the factory if the settings on your charger are incorrect.

If you suspect a problem, check the following:

1. Is AC power available to the charger?
2. Is the remote temperature sensor (RTS) connected, or has it been damaged?
2. Are any fuses blown?
3. Is the charger connected to a battery of the correct voltage?
4. Was the charger damaged in transit or installation?
5. If you determine that the charger is not working because it is not putting out any current, check the battery's state of charge. If the battery is fully charged it is normal for the charger to produce zero current. See Figure 4.1.
6. If the battery is being over- or undercharged, check whether the output voltage settings have been tampered with. The pots should be covered with either white adhesive paper dots or a hard red varnish.

2
Description and
Application

This manual covers installation, operation and troubleshooting of SENS model FC and FCA battery chargers rated at 6 or 10 amps output, 12, 24, 32 and 48 volts. Text, drawing of the housing mechanical layout, generic power circuit schematic, and circuit board replacement information are included. Complete parts lists and board-level documentation are available separately from SENS.

NOTE: The following units are UL listed to UL specification 1012:

- 12 or 24 volt output AND
- 120 volt input

3 Installation

3.1 Mounting *(for dimensions, refer to drawings at end of manual)*

Mount on a clean, dry, fixed wall that is protected from extremes of temperature. Allow at least 6 inches above and below the unit, and three inches either side for proper ventilation. The unit must be mounted vertically. If the charger must be mounted on or in a vibrating enclosure, the mounting arrangement should be designed to provide full vibration isolation. **Protect the charger from construction grit, metal chips, paint or other debris.** Clean away debris after installation.

FIGURE 3.1
FC Charger Mounting *(see diagram at end of document for dimensions)*

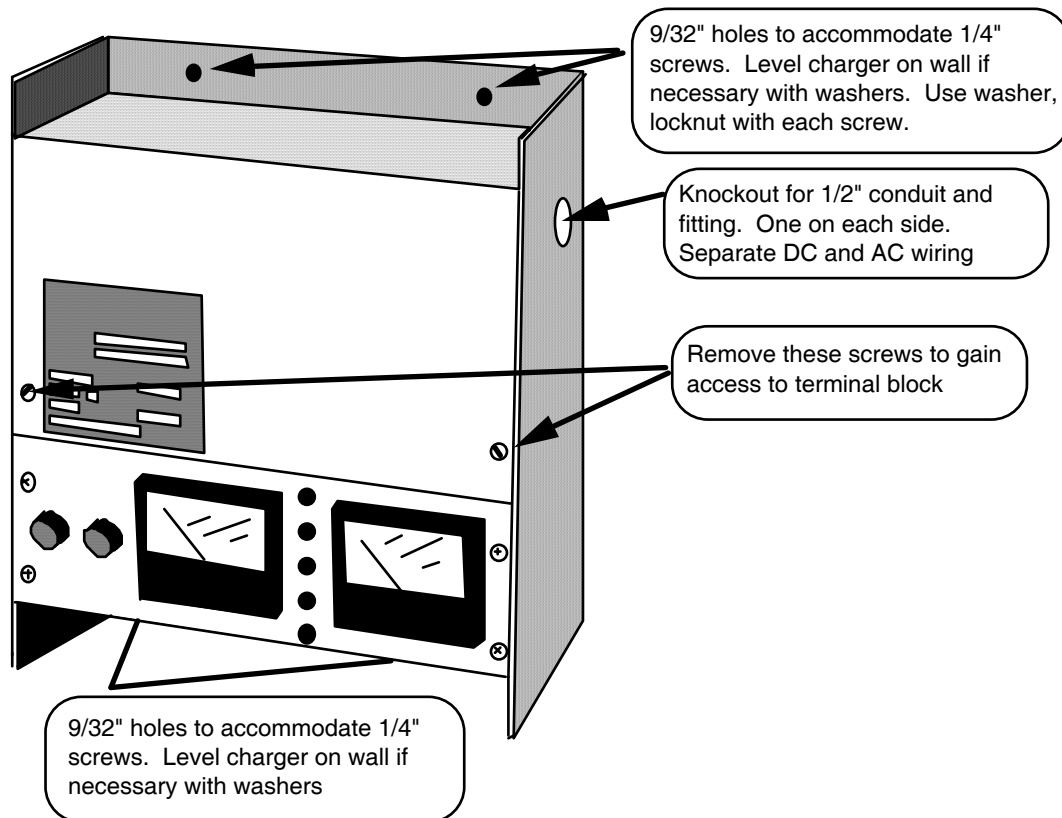

3.2 Power Connections

WARNING: FC/FCA chargers use different fusing configurations as follows:

115 & 277 volt, 60 Hz	Single pole input fuse
220 volt, 60 Hz*	2-pole input fuses (to protect two live leads - there is no neutral lead used)
220 volt, 50 Hz**	Single pole input fuse

Ensure that you have the correct fusing configuration.

1. *The neutral must NEVER be fused*

2. *The live conductors must be fused*

* All 60 Hz voltages except 115 and 277 use this configuration

** All 50 Hz voltages use this configuration unless specially ordered

Refer to the drawings at the back of this guide. Connection should be made by a qualified installer. Remove the two screws securing the charger's top front panel to gain access to the connections.

- Use AWG #12 or larger wire rated for 90C temperature or higher, for DC (charger to battery) leads.
- Use AWG #14 or larger wire rated for 90C temperature or higher, for AC input

and ground connections.

WARNING: The battery charger should be connected to a grounded permanent wiring system. A ground stud is provided for this purpose

Knockouts accommodating 1/2" conduit and fittings are located on each side of the charger. Run the AC wiring independent of the DC and alarm wiring.

The voltmeter will show battery voltage as soon as the DC connection is completed. *Check the voltmeter as soon as the FC connection has been made.* If the meter reads zero or is deflecting below zero, reverse the polarity of the battery connections. *Do not energize the charger with the battery connected backwards--the DC fuse will blow.*

3.3 Alarm Connections *(pertains only to FCA models)*

Caution: Connection to the alarms is somewhat delicate; complete instructions and detailed drawings are provided at the end of this guide. Use stranded wire, rather than solid, if it is available.

The alarm relays are rated for a maximum of 2 amps at 25 volts DC, or 0.5 amp at 120 volts AC (non-inductive loads only). Connect the alarm relay to customer-supplied supervisory system only -- *do not apply AC mains power to the relays and do not exceed the relays' ratings.*

Two versions of FCA alarm board are available; both meet NFPA 110:

<u>Condition</u>	<u>LED Indicator</u>	<u>FCA model suffix</u>
AC on	Green LED	-2211, -2411
Low battery voltage	Amber LED	-2211, -2411
Charger failure	Red LED	-2211, -2411
AC fail	Red LED	-2411 only
High battery voltage	Red LED	-2411 only

3.4 Remote Temperature Sensor

The remote sensor is connected to the charger by a wire pair. It must be secured on, or near the battery. Insure that the leads connecting the sensor to the charger are strain relieved, and otherwise protected from damage or disconnection.

4 Using the Charger

4.1 Features of the Charger

FC/FCA chargers feature **soft start circuitry**, which causes a gradual increase in output power after application of AC power. The **Autoboost system** causes the charger initially to operate at the high rate. When the charger reaches the boost voltage set point, and current has dropped to approximately 50% to 70% of the charger's rating, the charger will revert to the float mode. The transition from boost to float will cause the output current of the charger to drop to zero amps until the battery voltage drops to the float level. Once the battery voltage nears the float setting, the charger will again deliver a small amount of current to the battery to maintain it at its fully charged state. Figure 3 is a graph of how the Autoboost system works.

NOTE: Autoboost is disabled on chargers shipped for use with sealed lead-acid batteries, per the recommendation of most battery manufacturers.

The battery charger is **temperature compensated** to match the negative temperature coefficient of the battery. Thus the float voltage will increase slightly as the temperature decreases, and decrease as temperature increases. The battery charger is electronically **current limited** to 110% of rated output. The charger will reduce its current output when the battery voltage is lower than normal so that the charger's rated output power in watts is not exceeded.

The charger uses **True Voltage Sensing (TVS)** to automatically compensate for voltage drop in the charging leads. TVS senses current flow between output current pulses, when current flow and voltage drop are zero. TVS interacts with the battery, and therefore a battery is required for correct operation of the charger.

FIGURE 4.1

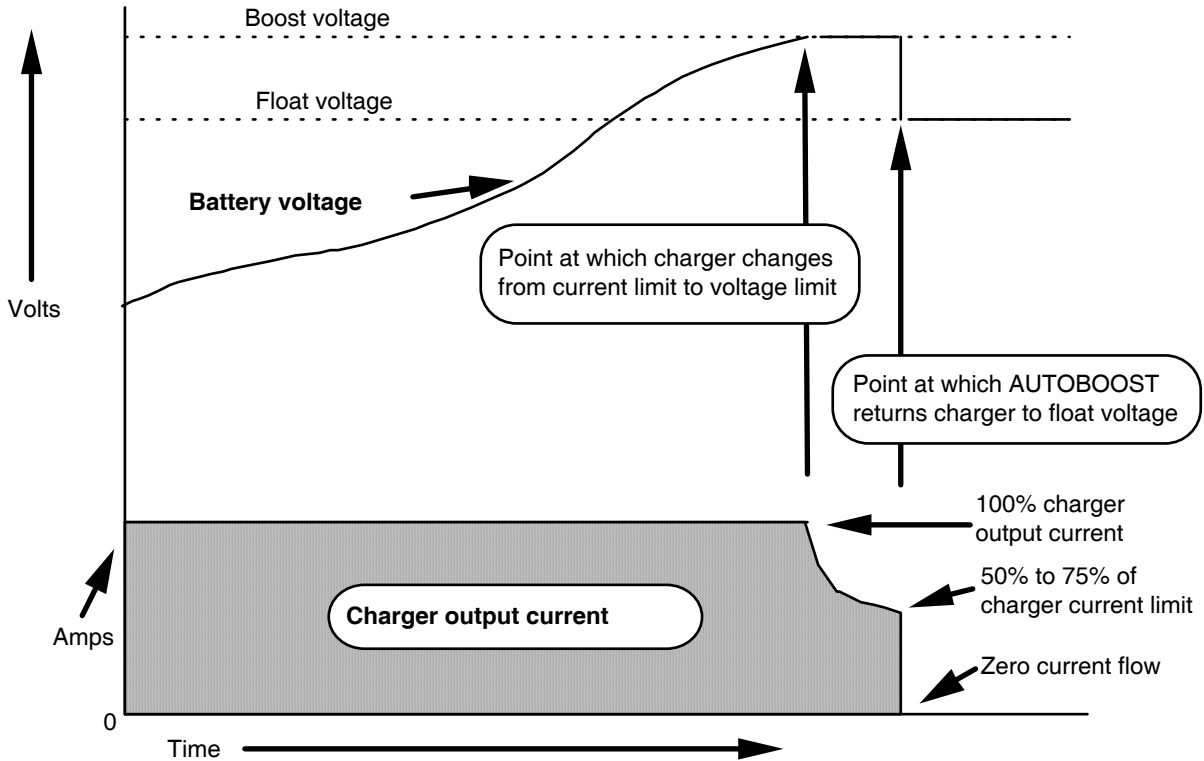

NOTE: When the charger switches from BOOST to FLOAT mode, no current will flow into the battery for a while due to the battery's high state of charge. **This is completely normal, and indicates that the charger is working properly.**

4.2 Ammeter, Voltmeter and Charger Troubleshooting

The voltmeter and ammeter (and alarm LEDs on the FCA models) provide indication of normal operation. Correct operation is indicated when the voltmeter reads 110% to 120% of nominal battery voltage. High current flow indicates that the battery has been discharged, and is being recharged. Low current flow normally indicates that the battery is fully charged. The charger will at times read 0 amps. This most commonly happens after the charger has reverted from the boost (or high rate) charge to float charge. *Do not* automatically assume that the charger has failed if the ammeter reads 0 amps!

4.3 Alarm Operation *(pertains only to FCA models)*

The alarm LEDs have the following meanings:

Power on: AC power is available to the charger

Charge fail: The charger senses voltage rather than current to detect "failure"; once battery voltage drops approximately 1 volt below nominal the alarm activates. This may occur when:

- a) The battery is fully discharged
- b) The AC power has failed, and the battery has become discharged
- c) There is an excessive load on the charger (not a charger failure)
- d) The charger has failed

There is a time delay of approximately one minute between the start of the alarm condition and the actual alarm signal. This prevents spurious indications during short-term deep battery discharge (as would happen during engine cranking).

AC fail: There is no AC power to the charger. This indicates either:

- a) The AC power has failed
- b) The input fuse is blown

High battery: Indicates that the output voltage is above a preset, adjustable point. The control circuit may have malfunctioned, or it could be misadjusted. In some cases, long leads of small gauge wire to the batteries cause a high battery alarm. The charger's *True Voltage Sensing* circuit automatically compensates for voltage drop in the charging leads. If charging leads are too small, the charger will operate at a high voltage to overcome high resistance in the leads. The alarm indication is made as soon as the alarm condition begins and lasts for approximately one minute after the alarm condition ends.

Low battery: Indication is made when the battery voltage is below a preset, adjustable point. This may occur when:

- a) The AC power has failed and the battery has become discharged
- b) The charger has malfunctioned
- c) The battery is defective

There is a delay of approximately one minute between the start of the alarm condition and the alarm signal. This prevents false indications due to engine cranking or other temporary deep battery discharge. The delay period can be adjusted. Consult the factory.

The FCA's alarm system includes a Form C contacts. The contacts change position whenever the associated alarm is activated.

When de-energized, the Form C contacts are in the "Failed" position (Fail and Com are connected)

4.4 Temperature Compensation (TC)

The charger's output voltage is designed to vary slightly with ambient temperature at the same rate that batteries demand different charging voltage at different temperature. The need to provide temperature compensation is a function of the battery, rather than the charger.

The temperature coefficient is -0.2% per degree C. At high temperatures the charging voltage will decrease and vice-versa. The benefits of the feature are superior battery performance at cold temperatures, less frequent need for watering in hot temperatures and longer battery life.

Placement of the remote temperature sensor at the battery insures that the charger reacts to temperatures at the battery, rather than at the charger.

5 Adjustments

Customer service of the charger is recommended only if the technician is experienced in electrical and electronic equipment. If a trained technician is not available, return the charger to the factory for adjustment. Note that adjustment of factory-set voltages without factory authorization voids the charger's warranty.

5.1 Adjusting the Charger Output Voltage *(refer to Figure 5)*

NOTE: There are two ways to adjust the charger voltage. The first method requires only an external precision voltmeter. The second method takes less time, but requires a 40-volt, 100,000-microfarad capacitor and an adjustable load.

NOTE: The charger *cannot* be correctly adjusted without either a battery or the capacitor mentioned above. This is because SENS' True Voltage Sensing circuit senses battery voltage only between charging current pulses.

All chargers *(adjustment procedure where capacitor and & load bank are not available)*

Connect an external precision voltmeter to the battery. Adjust the charger in small increments -- it takes time for the battery to adjust to new charger settings, so be patient.

1. Open upper front panel to gain access to control circuit.
2. Remove protective paper dots from potentiometers R30 and R34 (also labeled FLOAT and BOOST).
3. Turn boost voltage pot R34 fully counter clockwise.
4. Adjust float pot R30 in small increments until the battery reaches the desired voltage. The voltage is not stable until the current drops to about 1 to 2 amps. *Do not consider the adjustment final until charger current is this low!*
5. Turn the boost pot R34 fully clockwise (maximum output voltage).
Now adjust the boost charge voltage as described below:

Different adjustment procedures are used for AUTOBOOST and timed boost chargers.

AUTOBOOST chargers only *(not equipped with a timer)*

6. Put the charger in the AUTOBOOST mode by partially discharging the battery, then removing and restoring the charger's AC power source.
7. Allow the battery voltage to rise to the desired high rate charge level. Once at this voltage, carefully turn the boost pot counter-clockwise until the charger ammeter suddenly drops to approximately zero amps.
8. Charger is now adjusted. Replace paper dots and close front cover.

Chargers with timed boost

6. Turn timer knob to start high rate charging.
7. Allow the battery voltage to rise to the desired high rate charge level. The battery should be discharged so that charger is producing between 60% and 100% of its rated

current. Once at the desired boost voltage, carefully turn the boost pot counter-clockwise until the charger ammeter drops noticeably (to between 1/2 and 2 amps).
8. Charger is now adjusted. Replace paper dots and close front cover.

Alternative adjustment procedure using capacitor and load bank -- all chargers

The capacitor and adjustable load take the place of a battery, so you do not have to wait for the battery voltage to increase or decrease to new output voltage levels. The time delays in the alarm circuit, however, cannot be defeated.

Connect the capacitor in parallel with the output terminals, making sure that the polarity is correct. Use the same general adjustment procedure as the "all chargers" section above; setting changes, however, do not have to be made in small increments. For the float adjustment, adjust the load bank so that the charger puts out about one amp. For the boost adjustment, adjust the load bank so that the charger puts out about 80% of its rated current. This high load causes AUTOBOOST chargers to switch to high rate charge.

FIGURE 5

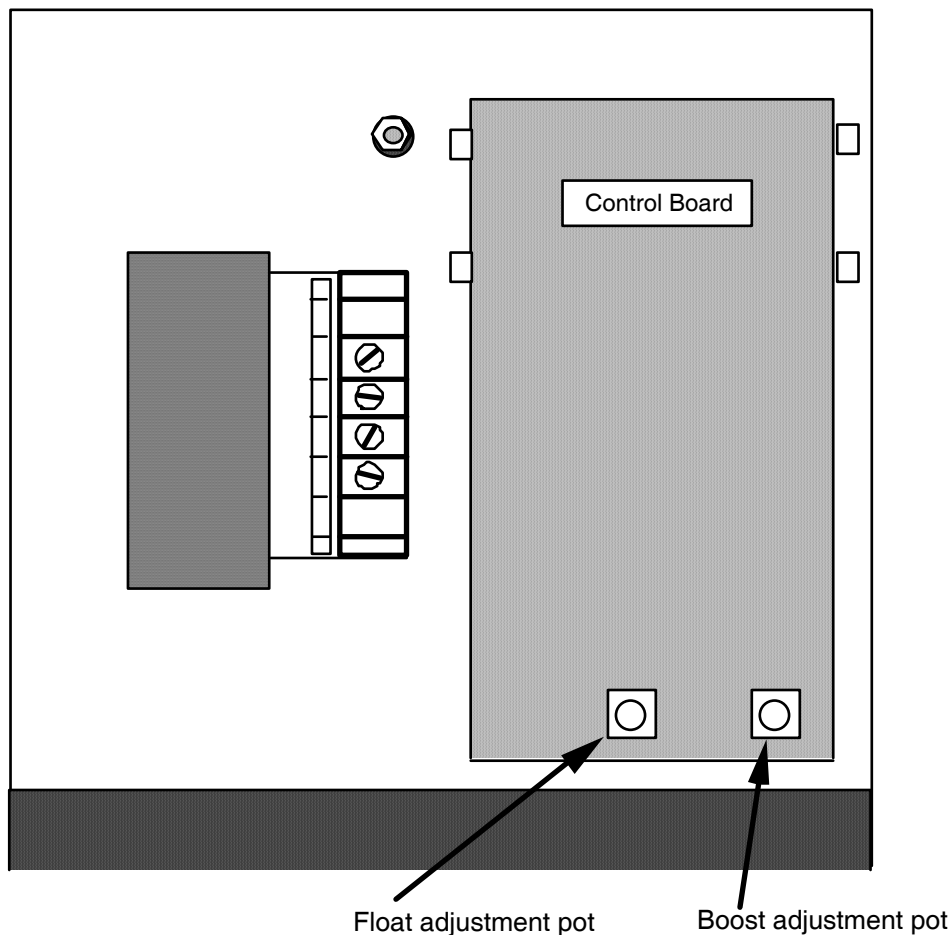

View of FC charger with upper and lower doors open

5.2 Factory-Set Output Voltages

Chargers set for liquid-electrolyte lead-acid battery

FC/FCA Charger Operation & Maintenance--6 & 10 amp units

	12 volt	24 volt	32 volt	48 volt
Float voltage	13.3	26.6	35.5	53.28
Boost voltage	14.0	28.0	37.3	56.00

Chargers set for sealed lead-acid battery

	12 volt	24 volt	32 volt	48 volt
Float voltage	13.5	27.0	36.0	54.24
Boost voltage	Boost should be turned all the way off for sealed battery.			

Chargers set for nickel cadmium battery

volt	12 volt	24 volt	32 volt	48
Float (# cells), voltage	(10) 14.3	(19) 28.8 (20) 28.6	(25) 38.0 (27) 38.6	(37) 52.9 (38) 54.3
Boost (# cells), voltage	(10) 15.2	(19) 28.6 (20) 30.4	(25) 38.0 (27) 41.0	(37) 56.2 (38) 57.8

5.3 Adjusting Alarm Voltage Levels

Three alarm adjustments are possible: charger failure alarm, low battery voltage alarm and high battery voltage alarm. The location of the adjustment potentiometers is shown in drawing no DIA\00066 at the end of this guide. Use an external precision voltmeter connected directly to the charger's output terminals.

To adjust the alarms, use an external adjustable DC power supply capable of providing up to 1/2 of an amp and an infinitely variable range of 10 to 50 volts.

De-energize the charger, disconnect the battery and connect the power supply's output leads to the charger's FC output terminals, being careful to observe correct polarity. Turn on the power supply. Verify on the external meter that polarity is correct.

Low battery alarm: Adjust the power supply to the desired alarm level. Turn the alarm pot counter-clockwise one revolution or so to increase the alarm voltage point. Wait until the alarm activates (about one minute). Now slowly turn the adjustment pot clockwise until the alarm light shuts off. This will be the voltage at which the adjustable power supply is set.

Charge fail alarm: Set this alarm using the same procedure as the low battery voltage alarm.

High battery alarm: Adjust the power supply to the desired level. Turn the alarm pot counter-clockwise one turn or so to reduce the alarm voltage to a low value. Now slowly turn the adjustment pot clockwise until the alarm light turns on. This will be the voltage at which the adjustable supply is set.

5.4 Factory-Set Alarm Voltages

Chargers set for lead-acid battery

	12 volt	24 volt	32 volt	48 volt
Low battery alarm voltage	11.0	22.0	30.0	44.0
High battery alarm voltage	16.0	32.0	40.5	60.0
Charge fail alarm voltage	12.0	25.0	34.0	50.0

Chargers set for nickel cadmium battery

	12 volt	24 volt	32 volt	48 volt
(# cells), low battery alarm voltage	(10) 11.9	(19) 22.6 (20) 32.12	(25) 29.75 (27) 32.15	(37) 48.1 (38) 49.4
(# cells), high battery alarm voltage	(10) 16.27	(19) 30.9 (20) 32.6	(25) 40.8 (27) 44.0	(37) 60.3 (38) 61.9
(# cells), charge fail alarm voltage	(10) 13.7	(19) 26.0 (20) 27.4	(25) 34.3 (27) 37.0	(37) 50.7 (38) 52.1

6 Trouble- shooting Guide (FC or FCA chargers)

6.1 SENS' Field Assistance Policy

SENS' policy is to help field technicians correct problems as fast and inexpensively as possible. We encourage you to telephone SENS on our toll-free line for help--it will save you time and trouble.

6.2 Troubleshooting Table

Symptom	Possible cause	Test	Repair procedure
No output	AC or DC fuse blown Battery not connected No AC power Ammeter disconnected TB-3 disconnected Defective control circuit Defective transformer	#1	Replace fuse Connect battery Restore AC Reconnect Reconnect
		#2	Call SENS for assistance Call SENS for assistance

FC/FCA Charger Operation & Maintenance--6 & 10 amp units

AC fuse blows	Wrong input voltage Defective control circuit	#3	Connect to correct voltage Call SENS for assistance
DC fuse blows	Defective control circuit Battery leads reversed		Call SENS for assistance Call SENS for assistance
Overcharging	Improper boost/float settings Defective control circuit	#4	Adjust output voltages Call SENS for assistance
Undercharging	Improper boost/float settings Defective control circuit	#4	Adjust output voltages Call SENS for assistance

Alarm Indications
(FCA units only)

Indication	Possible cause	Test	Repair procedure
AC fail	AC fuse blown No AC power Defective alarm circuit	#1	Replace AC fuse Restore AC Call SENS for assistance
Charge fail	AC or DC fuse blown No AC power Excessive load Battery voltage low Defective alarm circuit	#1 #5	Replace AC fuse Restore AC Reduce load Dead battery Call SENS for assistance
High DC	Improper voltage settings Defective control circuit Defective alarm circuit	#4	Adjust output/alarm voltages Call SENS for assistance Call SENS for assistance
Low DC	AC fuse blown DC fuse blown No AC power Excessive load Defective alarm circuit	#1 #1 #5	Replace AC fuse Replace DC fuse Restore AC Reduce load Call SENS for assistance

FIGURE 6

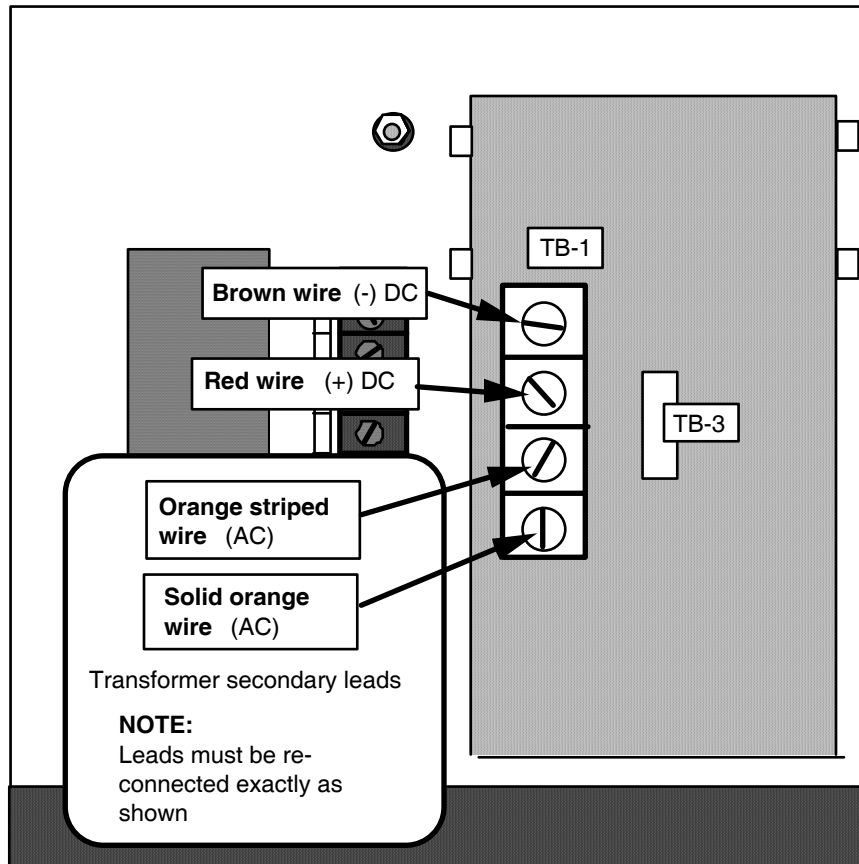

7 Test Procedures

Test #1: Remove the fuse and measure its resistance using an ohmmeter on the Rx1 range. Meter should read 0 ohms for a good fuse.

Test #2: Energize the charger after disconnecting the secondary leads from the control board and measure the secondary voltage. Do not short-circuit the leads while performing this test. The AC voltage should be 1.5 to 2 times the nominal output voltage of the charger. The control winding (TB3A) should be approximately 10-14 volts AC rms. See Figure 6 below for location of leads.

Test #3: Check the information on the nameplate to insure it agrees with the AC voltage applied.

Test #4: Measure the battery voltage using a 1% accuracy voltmeter. If the charger's voltage is not set properly for your batteries, adjust float/boost settings according to the adjustment procedure.

Test #5: Loads greater than the charger's rating will cause the control circuit to reduce output voltage so that the total output power in does not exceed the charger's rating. This is normal with a dead or deeply discharged battery.

5.3 Adjusting Alarm Voltage Levels

Three alarm adjustments are possible: charger failure alarm, low battery voltage alarm and high battery voltage alarm. The location of the adjustment potentiometers is shown in drawing no DIA\00066 at the end of this guide. Use an external precision voltmeter connected directly to the charger's output terminals.

To adjust the alarms, use an external adjustable DC power supply capable of providing up to 1/2 of an amp and an infinitely variable range of 10 to 50 volts.

De-energize the charger, disconnect the battery and connect the power supply's output leads to the charger's FC output terminals, being careful to observe correct polarity. Turn on the power supply. Verify on the external meter that polarity is correct.

Low battery alarm: Adjust the power supply to the desired alarm level. Turn the alarm pot counter-clockwise one revolution or so to increase the alarm voltage point. Wait until the alarm activates (about one minute). Now slowly turn the adjustment pot clockwise until the alarm light shuts off. This will be the voltage at which the adjustable power supply is set.

Charge fail alarm: Set this alarm using the same procedure as the low battery voltage alarm.

High battery alarm: Adjust the power supply to the desired level. Turn the alarm pot counter-clockwise one turn or so to reduce the alarm voltage to a low value. Now slowly turn the adjustment pot clockwise until the alarm light turns on. This will be the voltage at which the adjustable supply is set.

5.4 Factory-Set Alarm Voltages

Chargers set for lead-acid battery

	12 volt	24 volt	32 volt	48 volt
Low battery alarm voltage	11.0	22.0	30.0	44.0
High battery alarm voltage	16.0	32.0	40.5	60.0
Charge fail alarm voltage	12.0	25.0	34.0	50.0

Chargers set for nickel cadmium battery

	12 volt	24 volt	32 volt	48 volt
(# cells), low battery alarm voltage	(10) 11.9	(19) 22.61 (20) 23.8	(25) 29.75 (27) 32.13	(37) 44.03 (38) 45.22
(# cells), high battery alarm voltage	(10) 16.27	(19) 30.9 (20) 32.6	(25) 40.8 (27) 44.0	(37) 60.3 (38) 61.9
(# cells), charge fail alarm voltage	(10) 13.7	(19) 26.0 (20) 27.4	(25) 34.3 (27) 37.0	(37) 50.7 (38) 52.1

6 Trouble- shooting Guide (FC or FCA chargers)

6.1 SENS' Field Assistance Policy

SENS' policy is to help field technicians correct problems as fast and inexpensively as possible. We encourage you to telephone SENS on our toll-free line for help--it will save you time and trouble.

6.2 Troubleshooting Table

revisions			
ltr	description	date	app
A	ENLARG. DIMS. CHNG. ALARM CONNECTION NOTES	6-92	WK

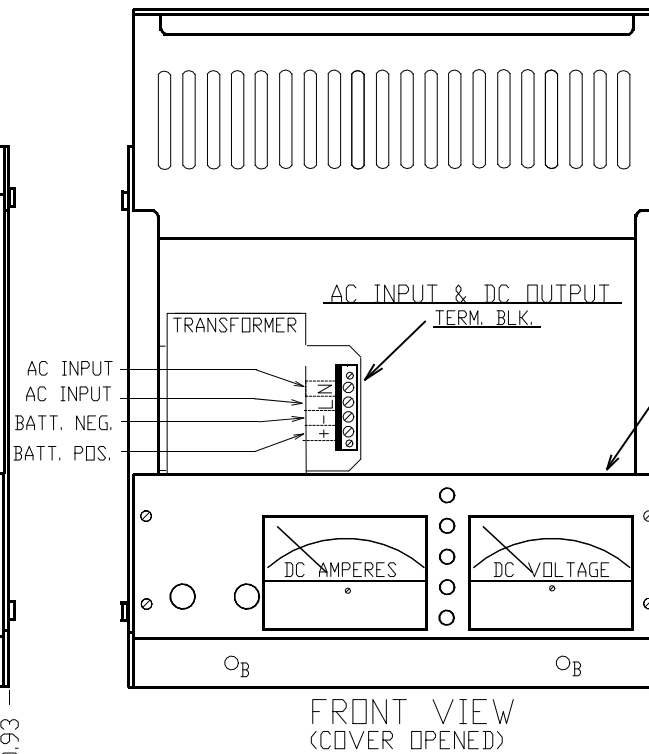
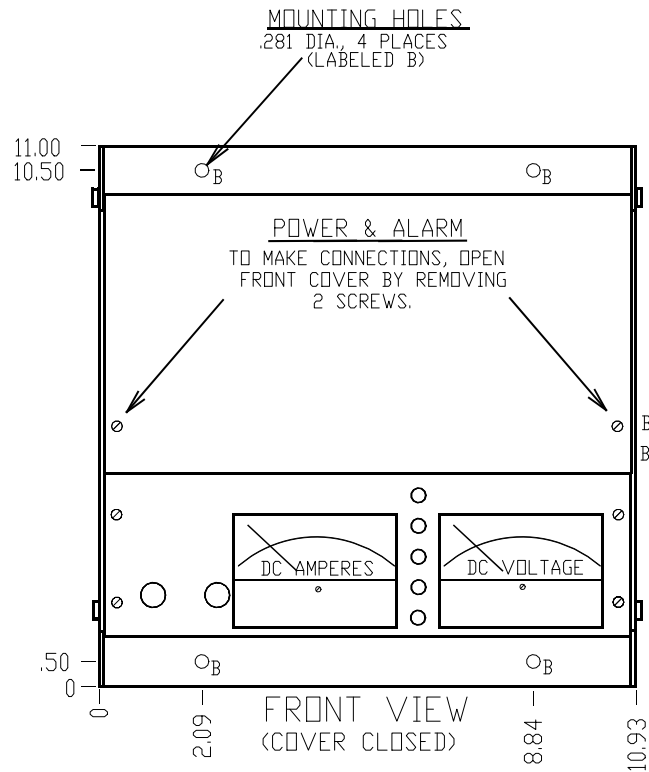

tolerances (unless otherwise specified) fract. dec. angles +.015 +.015 +.015 +.015		SENS STORED ENERGY SYSTEMS LONGMONT, CO	
		engineer: drawn: KAG checked: date: 6-19-91	description: FCA-1 CONN. & MOUNTING DIAGRAM code: 10 size: N/A DIA\00063A DO NOT SCALE DRAWING
		page: 1 of 1	

revisions			
ltr	description	date	app
A	REVISE VIEWS TO CLARIFY, DELETE 4 ALARM VERSION.	9-27-91	WFK
B	CORRECT ADJ. NOTES	4-1-92	WFK

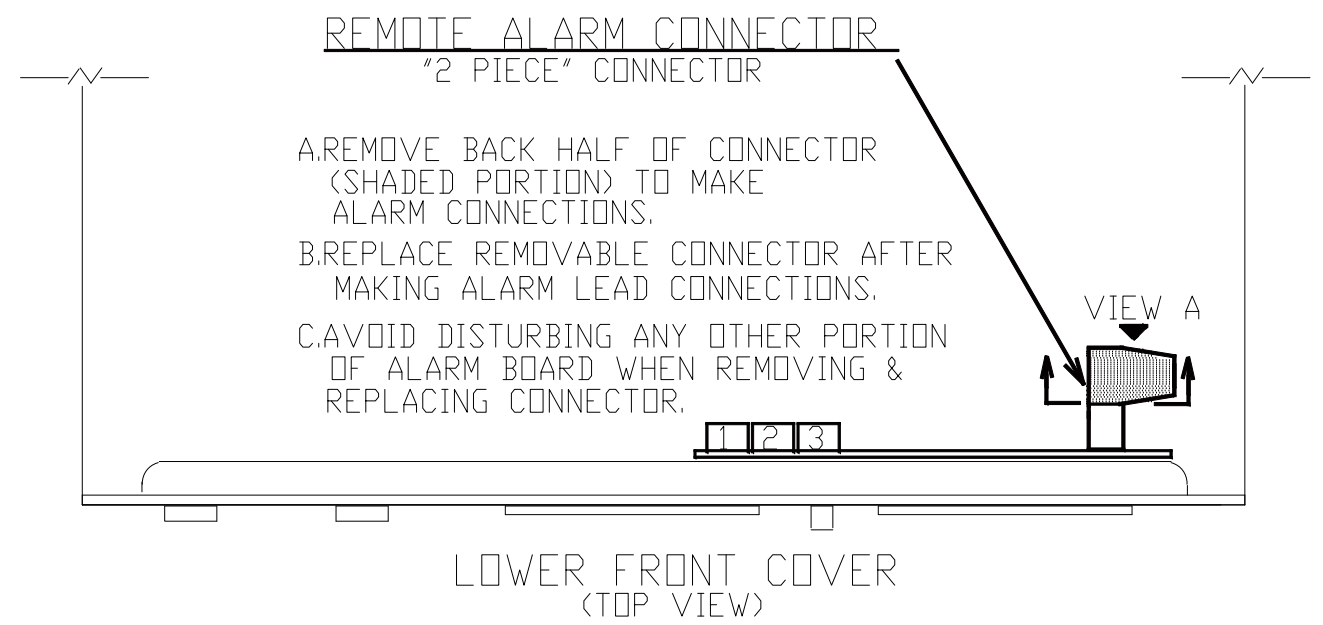
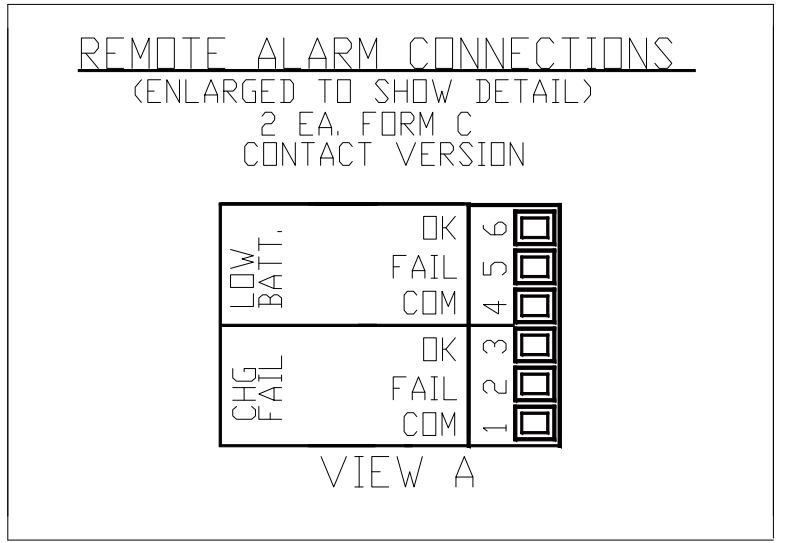
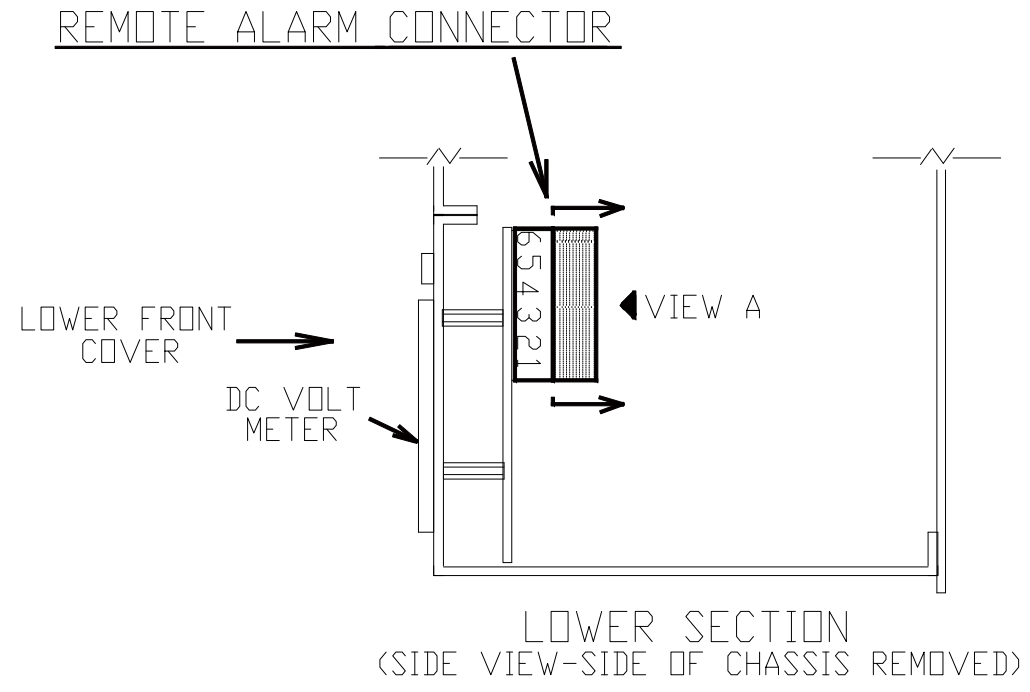

*NOTE: SHADING REPRESENTS REMOVABLE PORTION OF CONNECTOR.

- ADJUSTMENTS
- 1.CHG FAIL
 - 2.LOW DC
 - 3.HIGH DC

tolerances: (unless otherwise specified) fract. dec. angles		STORED ENERGY SYSTEMS Longmont, CO description FCAVV-AA-X2XX
	prepared KAG checked engineer	2-ALARM REMOTE ALARM CONN. DIA
	date 6-23-91	size drawing no. DIA\00066 rev
	scale: NONE	sheet 1 of 1



SENS Limited Warranty Policy

What is covered:

This warranty covers any defect in material and workmanship on battery chargers manufactured by Stored Energy Systems, a Colorado Limited Liability Company (SENS).

What this warranty does not cover:

This warranty does not cover damages, defects or failures of your equipment resulting from shipping damage, accidents, installation errors, unauthorized adjustment or repair, unauthorized third-party service, failure to follow instructions, misuse, fire, flood, acts of persons not in our control, and acts of God.

For how long:

Two years from date of shipment.

What we will do:

If your battery charger is defective within two years of date of shipment, we will repair it or, at our option, replace it at no charge to you.

If we choose to replace your charger, we may replace it with a new or refurbished one of the same or similar design. The repair or replacement will be warranted for the remainder of the original two-year warranty period. If we determine that your charger cannot be repaired or replaced, we will refund its purchase price to you.

What we ask you to do:

First contact SENS service department to obtain warranty service instructions. To obtain warranty service the product must be returned, freight prepaid, to the factory under a Return Merchandise Authorization (RMA) number provided by SENS. If, in SENS' opinion, the problem can be rectified in the field, SENS may elect to ship replacement parts for customer installation instead of having the product returned to the factory.

Limitation:

This warranty is limited to defects in material or workmanship of the product. It does not cover loss of time, inconvenience, property damage or any consequential damages. Repair, replacement or refund of the purchase price of the equipment is your exclusive remedy.